

the
59 FORDS



THE WORLD'S MOST BEAUTIFULLY PROPORTIONED CARS

FORD BRINGS THUNDERBIRD ELEGANCE TO THE LOW-PRICE FIELD

Every so often a car is born so perfect in *proportion* that it is internationally acclaimed a Classic. Such a car is the 59 Ford . . . awarded the Gold Medal for exceptional styling by the Comité Français de l'Élégance at the Brussels World's Fair!

Elegant lines and beautiful proportions distinguish each one of these 19 new Ford models . . . lines that unmistakably reflect Thunderbird breeding. You'll find more glass area . . . more length . . . more luxury.

You'll get responsive power at speeds between 30 and 70 mph—yet with greater savings. All standard engines—Six or Thunderbird V-8—are designed to thrive on *regular* gasoline. (You save up to 5¢ a gallon compared to premium gas!) New aluminized mufflers will normally last twice as long as conventional types used on other cars. Full-flow oil filtration (*standard* equipment on all Fords!) means you need change oil only after each 4000 miles instead of the 1000 miles often recommended.

But with all their economy . . . all their beauty . . . all their performance . . . you'll be pleasantly surprised to discover that these beautiful 1959 Fords are *still* priced Ford-low.



AWARDED THE GOLD MEDAL
of the Comité Français de l'Élégance
AT THE BRUSSELS WORLD'S FAIR
"Pour proportions exceptionnelles
et la ligne élégante"

"With Ford's new Diamond Lustre Finish she'll be able to see herself years from now, too!"

THE NATIONAL "OPEN" CHAMPIONS ARE FORDS

Not even the highest-priced cars in America offer you as *wide* a choice of convertibles as Ford! For only Ford offers you *three* excitingly different convertibles for '59! One is the world's *best-selling* convertible (Ford's Sunliner) . . .

another is the world's only *hardtop* convertible (Ford's Skyliner) . . . and the third is the world's most *admired* convertible (Ford's Thunderbird). Isn't it about time that *you* got that new Ford feeling . . . in a brand-new Ford convertible?



GERANIUM AND COLONIAL WHITE, STYLE TONE

THE FAIRLANE 500 SKYLINER

Introduced in 1957 after years of research, the Ford Skyliner still is the world's only retractable hardtop . . . another example of the years-ahead engineering you get in *every* Ford. Just touch a button and the Skyliner converts from all-steel hardtop to sun-loving convertible in 60 seconds!

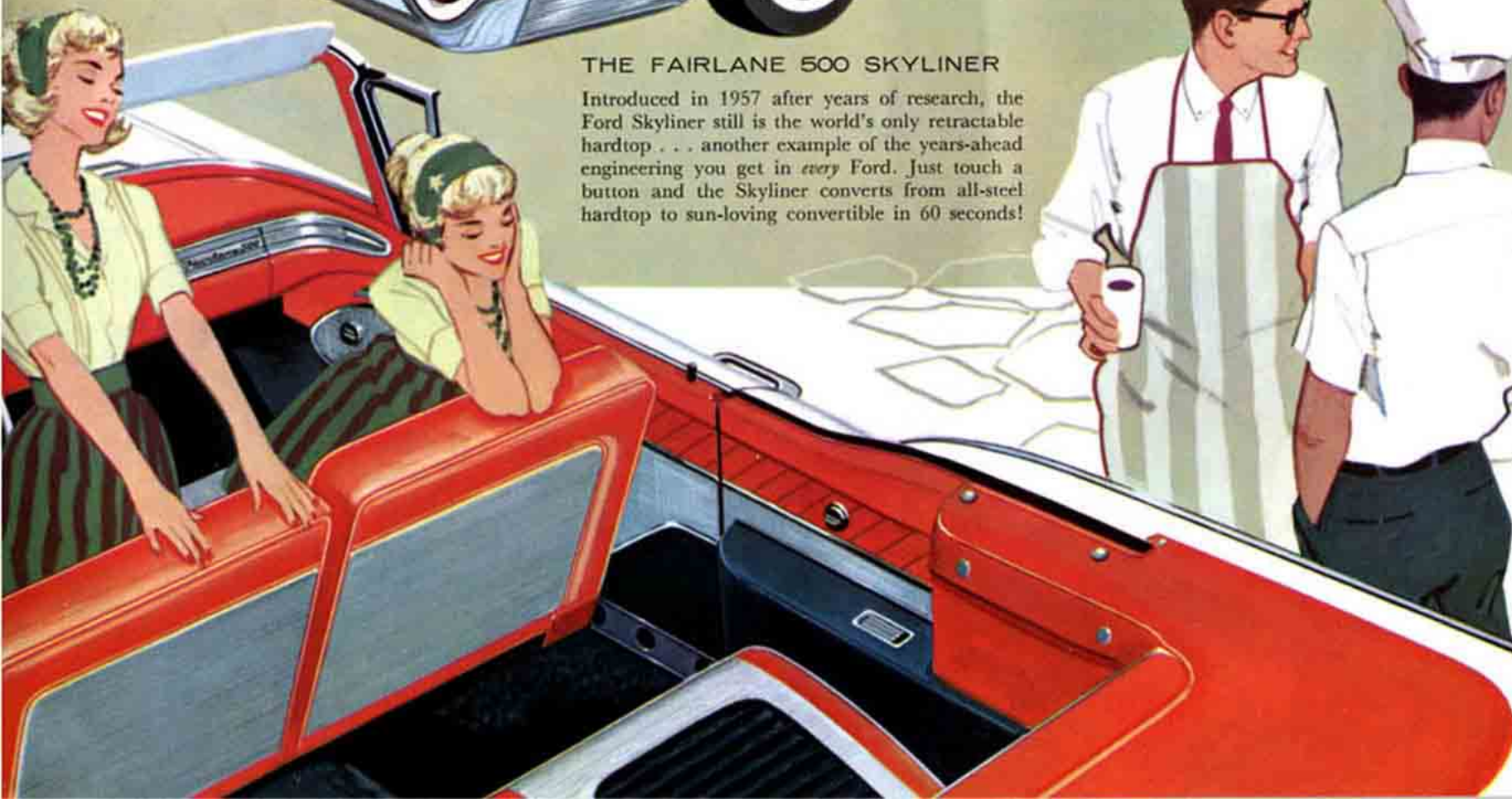

THUNDERBIRD CONVERTIBLE IN HICKORY TAN

THE 4-PASSENGER THUNDERBIRD

Another departure from conventional automot design is this incomparable four-passenger Thund bird convertible! Here is the most wanted . . . m talked-about car of the year. It gives all the luxu of a big town car . . . all the *fun* of a Thunderbi

RAVEN BLACK AND COLONIAL WHITE, STYLE TONE

THE FAIRLANE 500 SUNLINER

Here is the world's most popular convertible . . . now more lovely, more lively, and more tastefully styled than ever! With new flowing lines outside and color-keyed glamour inside, the Sunliner brings you authentic Thunderbird elegance . . . at low Ford prices.

"Only Ford offers you three entirely different convertibles!"

INTRODUCING THE WORLD'S MOST BEAUTIFULLY PROPORTIONED HARDTOPS!

Here is a totally new direction in pillarless or "hardtop" design. Like the fabulous Thunderbird, these graceful new Ford Victoria models are a picture of perfect proportions. Their new flowing lines are casually elegant . . . their new Thinline Roofs give you a wonderful new outlook . . . their bright-metal highlights are in perfect taste. Here, indeed, is a breath of Thunderbird at low Ford prices!

"I've never driven a car that handles so gently!"

"Picture windows all around give me a feeling of outdoor living!"



TANITIAN BRONZE AND FAWN TAN, STYLE TONE

THE FAIRLANE 500 CLUB VICTORIA

Ford designers have captured the true spirit of the Thunderbird in the clean, uncluttered lines of this car. Notice the beauty of its Flying V Rear Deck . . . highlighted by new Iris Eye Safety Taillights! Something else you'll appreciate is picture-window visibility all around. The whole car has a wide-openness, a straight-through look you'll love!

Ribbed Panel Trim

Adding new glamour to every Fairlane 500 is this bright-metal ribbed panel on the rear quarter. Matching Curb-Guard body molding is optional at extra cost.

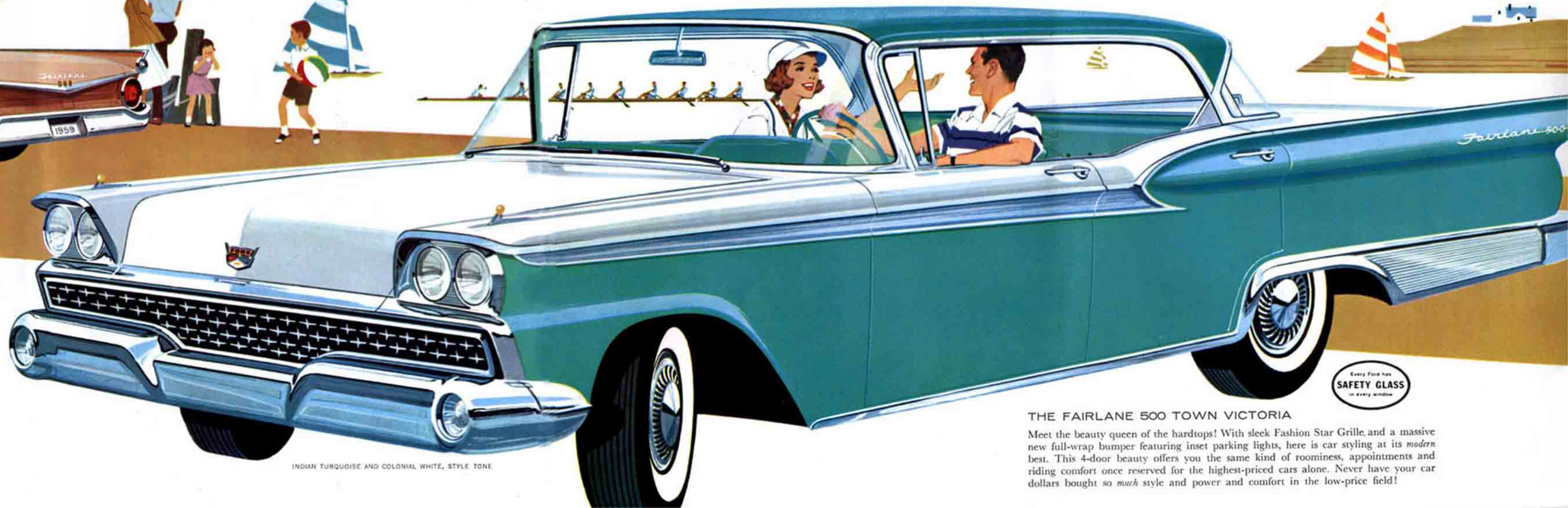

INDIAN TURQUOISE AND COLONIAL WHITE, STYLE TONE

THE FAIRLANE 500 TOWN VICTORIA

Meet the beauty queen of the hardtops! With sleek Fashion Star Grille and a massive new full-wrap bumper featuring inset parking lights, here is car styling at its *modern* best. This 4-door beauty offers you the same kind of roominess, appointments and riding comfort once reserved for the highest-priced cars alone. Never have your car dollars bought so *much* style and power and comfort in the low-price field!



THE FAIRLANE 500 TOWN AND CLUB SEDANS

In the new Ford Sedans for '59 you'll observe the same casual kind of elegance—the same fresh crispness of design that distinguishes the Thunderbird. They are beautifully different from all other cars—and from all other Fords. Both models shown on these pages feature Ford's attractive, thin-pillar "hardtop" styling.

"That new Ford rides so smooth you'd almost think you were flying!"

FAIRLANE 500 TOWN SEDAN

Despite its low-slung silhouette, this 4-door sedan is built for graceful entries and easy exits. It offers you a choice of high-styled Luxury Lounge interiors . . . as well as thick Luxury-Loom carpeting. You've never seen a car so rich in luxury . . . so *reasonably* priced!

WEDGEWOOD BLUE AND COLONIAL WHITE, TWO TONE



SHERWOOD GREEN AND COLONIAL WHITE, STYLE TONE

FAIRLANE 500 CLUB SEDAN

This boldly handsome 2-door sedan is a wonderful choice as a *family* car. It has plenty of room for six people and plenty of room for luggage, too. And like all Fords, it offers a choice of gas-saving engines . . . Six or Thunderbird V-8!

Iris Eye Safety Taillights

Only Ford offers you the safety of king-size Iris Eye Safety Taillights on *all* models. Because these lights are far more noticeable they keep you safer when you drive after dark.

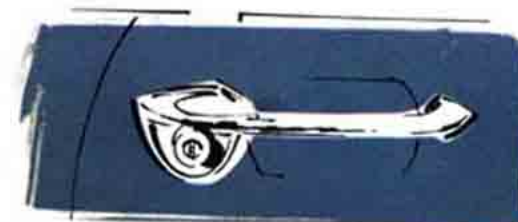

New Door Handle has the locking cylinder inside the push button for greater convenience and safety. You no longer have to lift a cover to insert the key.

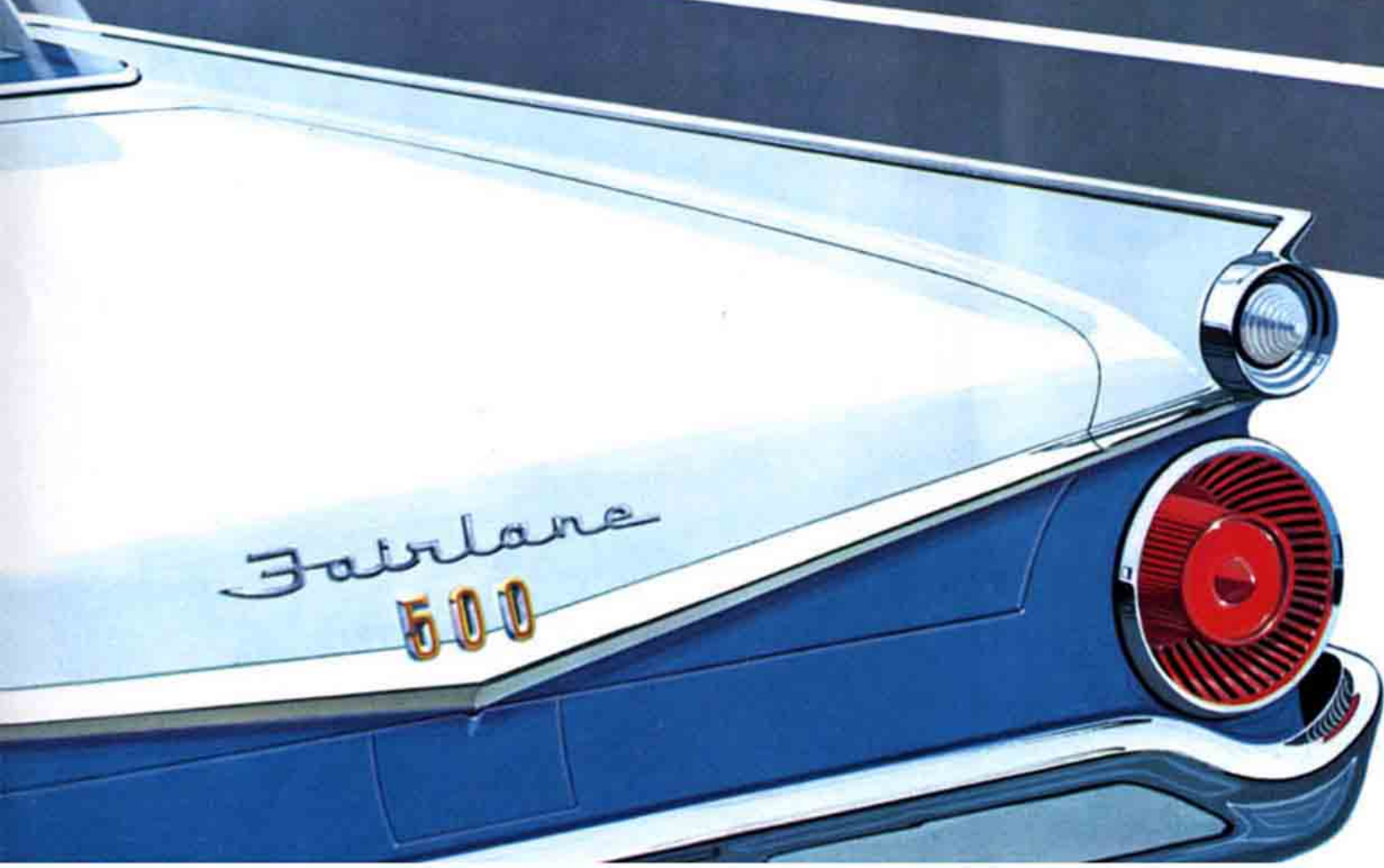

PRESENTING THE FAIRLANE SERIES

The handsome new Fairlanes for 1959 offer the same beautiful proportions as their sister series, the Fairlane 500's. And like all Fords they feature amazing new Diamond Lustre Finish . . . so durable you won't have to wax it—*ever!* Most surprising of all, these new Fairlanes are remarkably *low* in price.

"Nancy, your decorations are as elegant as a '59 Ford!"

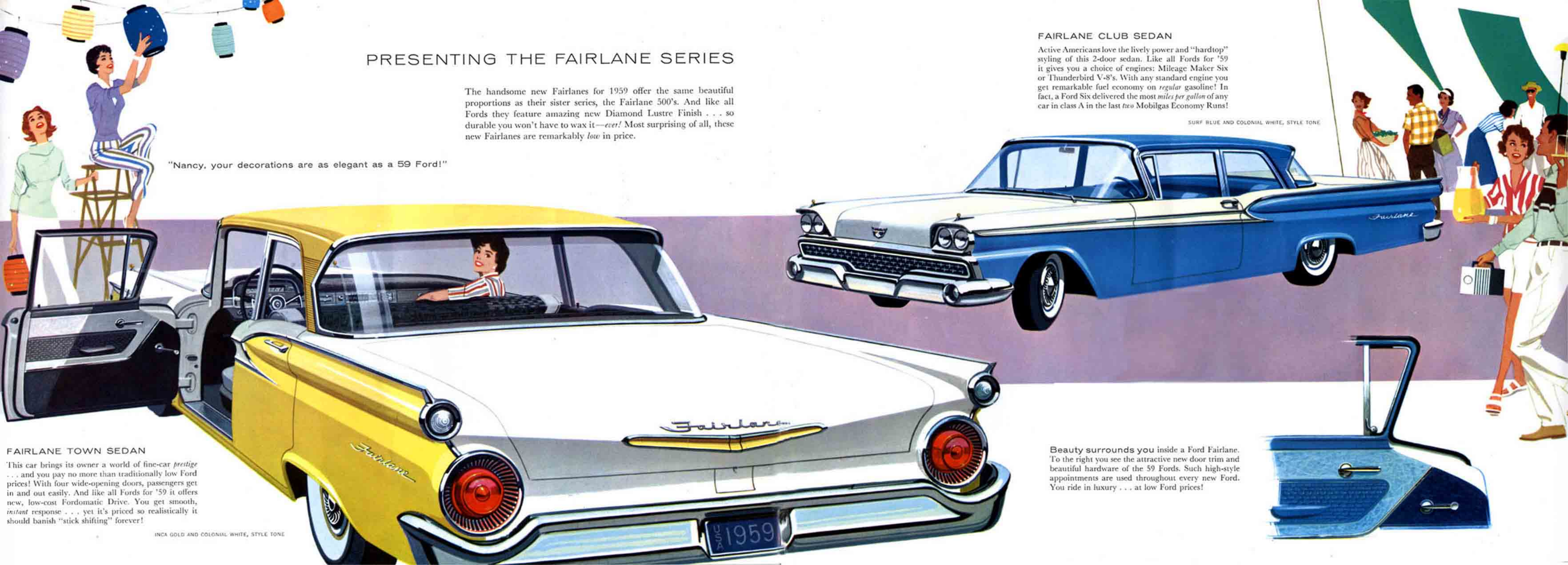

FAIRLANE CLUB SEDAN

Active Americans love the lively power and "hardtop" styling of this 2-door sedan. Like all Fords for '59 it gives you a choice of engines: Mileage Maker Six or Thunderbird V-8's. With any standard engine you get remarkable fuel economy on *regular* gasoline! In fact, a Ford Six delivered the most *miles per gallon* of any car in class A in the last *two* Mobilgas Economy Runs!

SURF BLUE AND COLONIAL WHITE, STYLE TONE

FAIRLANE TOWN SEDAN

This car brings its owner a world of fine-car *prestige* . . . and you pay no more than traditionally low Ford prices! With four wide-opening doors, passengers get in and out easily. And like all Fords for '59 it offers new, low-cost Fordomatic Drive. You get smooth, *instant* response . . . yet it's priced so realistically it should banish "stick shifting" forever!

INCA GOLD AND COLONIAL WHITE, STYLE TONE

Beauty surrounds you inside a Ford Fairlane. To the right you see the attractive new door trim and beautiful hardware of the '59 Fords. Such high-style appointments are used throughout every new Ford. You ride in luxury . . . at low Ford prices!

PRESENTING THE CUSTOM 300 SERIES

Once you compare Ford's Custom 300 models for 1959 with other cars, we believe you'll agree: none offers so much *value* for so little money as the Ford Custom 300's. Now, for the first time, these Custom 300's are built on *exactly* the same wheelbase as the most

expensive Fairlane 500 models! They're six inches longer than last year, and they're beautifully proportioned in every way. *Compare* and you'll agree that these Custom 300's are the true *value leaders* of the entire automotive field!

"Tom's new Custom 300 is this much longer than his old one!"



TORCH RED AND COLONIAL WHITE, STYLE TONE, with optional exterior trim

CUSTOM 300 FORDOR SEDAN

Who would ever suspect that a modest Custom 300 price could bring you such *four-door* convenience . . . such deep-down comfort for *six* passengers? And like the fabulous Thunderbird itself, this car is a picture of perfect proportions!



FAWN TAN AND COLONIAL WHITE, STYLE TONE, with optional exterior trim

CUSTOM 300 TUDOR SEDAN

Styled, powered and priced for today's driving, this two-door, six-passenger beauty handles so gently that you are barely aware you are driving. As with all '59 Fords it has Thunderbird-design steering . . . closest thing yet to *power* steering!



RAVEN BLACK, SINGLE COLOR

CUSTOM 300 BUSINESS SEDAN

This businessman's "special" gives you all of the penny-pinching economy, rugged dependability, comfortable riding qualities that you find in every Custom 300, and it is priced lowest of all. It offers an unusual value in modern, low-cost transportation . . . for big fleets . . . for the individual businessman . . . or for personal use.



This cutaway view shows you all the *extra* storage space behind the three-passenger front seat. This carrying area has a level floor that is five feet wide by two-and-a-half feet long. This is in addition to Ford's big trunk space with its handy counterbalanced deck lid.



New Instrument Panel

Styled and engineered for the greatest possible passenger safety, Ford's all-new Safety-Curved instrument panel for '59 is as practical as it is attractive.

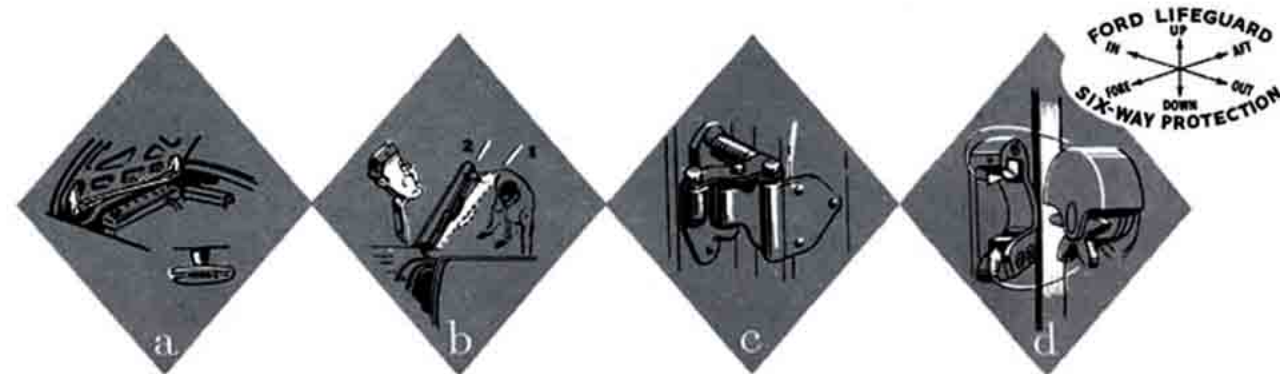

FORD LIFEGUARD
UP
IN
FOR
DOWN
OUT
SIX-WAY PROTECTION

- a **Front-hinged hood** has new torsion bar hinge for easier, counterbalanced action. Release control is inside car for security.
- b **Two-stage door checks** hold front door open in two positions: two-thirds or all the way. Features heavier, stronger bolts.
- c **Automatic doorman hinges** help swing the bigger rear doors full-open or full-closed. They are sturdier and have larger bolts than ever before.
- d **Lifeguard Double-Grip door locks** rotate rather than slide into engagement for effortless ease of operation in all weather.



NEW DIAMOND LUSTRE FINISH... most durable on any car today!

Ford's new Diamond Lustre Finish is the first major advance in automotive enamel finishes since World War II. It is the most durable finish offered on any car today! What's more, it's so bright and glossy that *you won't have to wax it... ever!*

The superiority of this new, longer-lasting, baked-on enamel was proved first in laboratory torture tests. Then it was applied on hundreds of cars and subjected

to scaring tropical sunlight and corrosive salt air for months. And Diamond Lustre remained showroom-bright far longer than the best finishes on other cars!

Finally, Ford engineers went after this finish with a BB gun. (The impact of air rifle pellets simulates flying stones and gravel.) And again, Diamond Lustre *proved* its toughness... proved it's *far* more chip-resistant than Ford's famous enamels of the past!

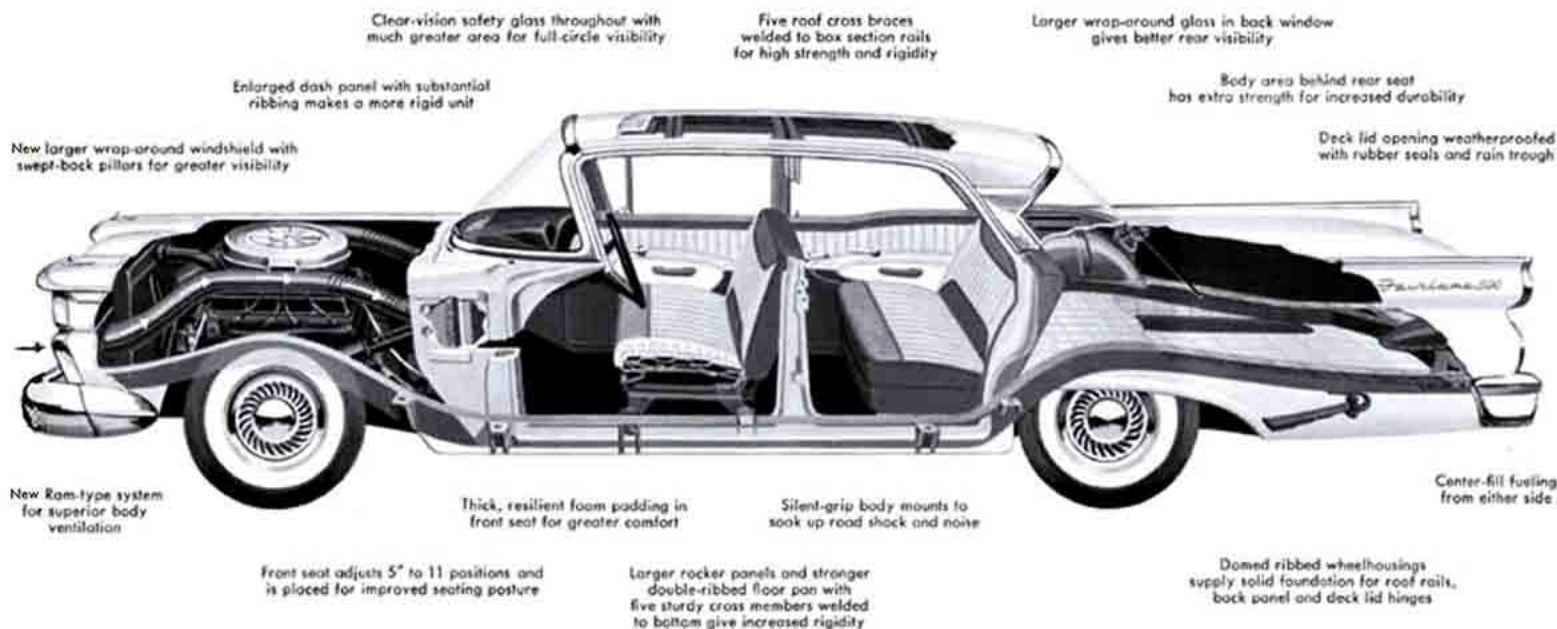

Clear-vision safety glass throughout with much greater area for full-circle visibility

Five roof cross braces welded to box section rails for high strength and rigidity

Larger wrap-around glass in back window gives better rear visibility

Enlarged dash panel with substantial ribbing makes a more rigid unit

Body area behind rear seat has extra strength for increased durability

Deck lid opening weatherproofed with rubber seals and rain trough

New larger wrap-around windshield with swept-back pillars for greater visibility

Center-fill fueling from either side

New Ram-type system for superior body ventilation

Thick, resilient foam padding in front seat for greater comfort

Silent-grip body mounts to soak up road shock and noise

Front seat adjusts 5" to 11 positions and is placed for improved seating posture

Larger rocker panels and stronger double-ribbed floor pan with five sturdy cross members welded to bottom give increased rigidity

Domed ribbed wheelhousings supply solid foundation for roof rails, back panel and deck lid hinges

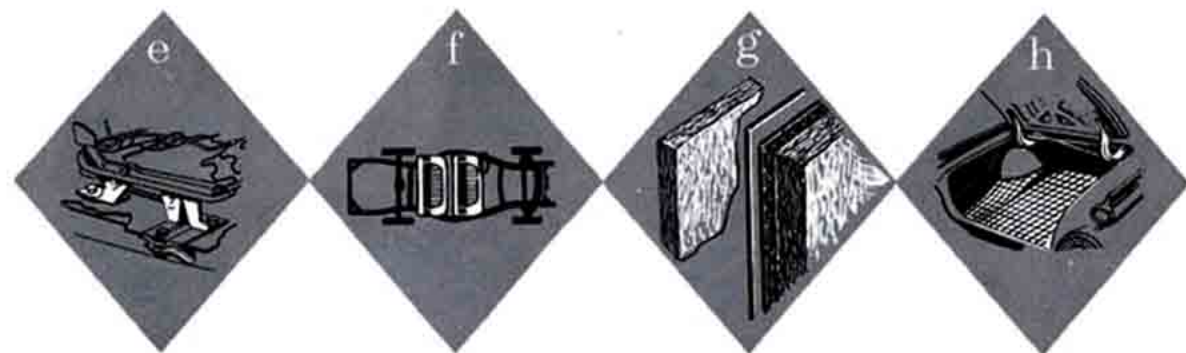

- e **Front seat safety anchorage** locks the heavy track structure to the chassis frame. Heavy "stops" help to hold the tracks together in case of impact.
- f **Ford's husky frame bows out** a full foot wider midway so that passengers ride *within* the heavy frame side rails. This is extra protection in case of accident.
- g **The best insulation** in Ford's field includes a half inch of fibrous sound-absorption material in the roof, one inch of glass fibre, felt and finish board on dash.
- h **New torsion bar hinging** of the deck lid provides better counterbalancing, more trunk capacity and prevents damage to luggage.

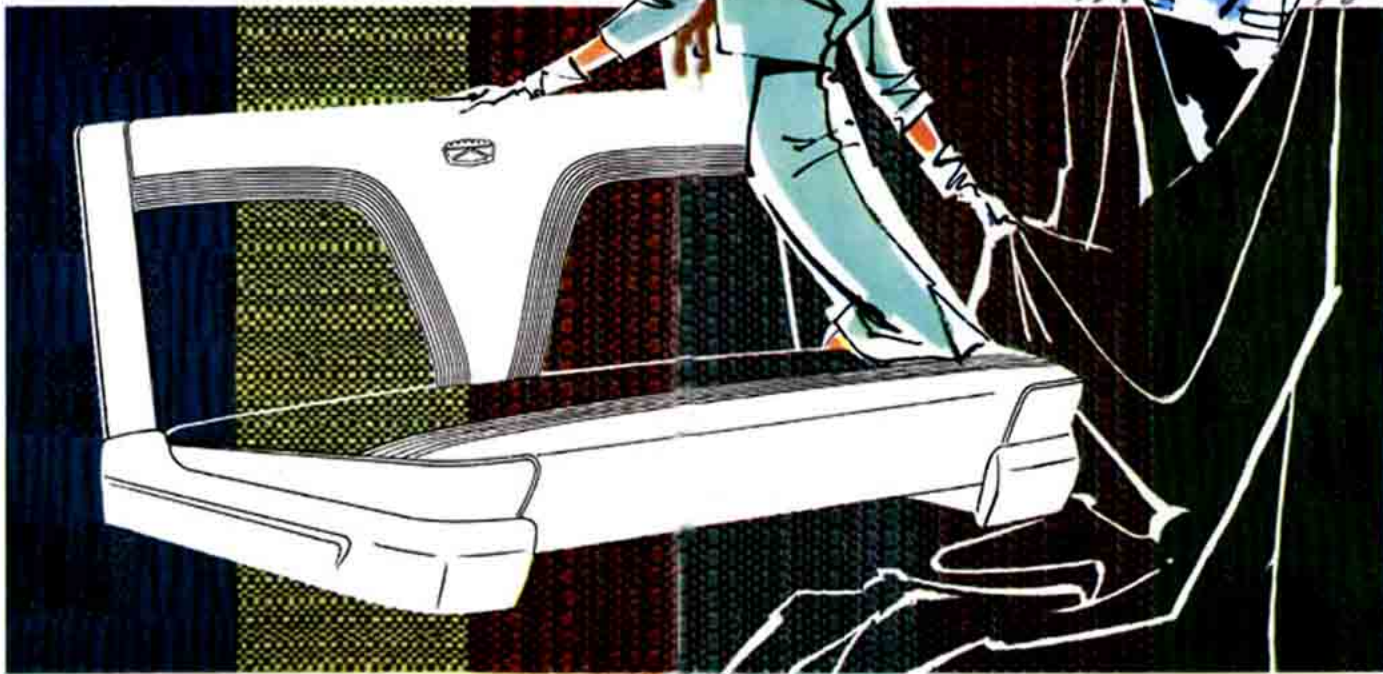

Since introducing the very *first* color-keyed interiors to the low-price field in 1951, Ford has always set the styling pace with its beautiful Luxury Lounge interiors. Now for '59, Ford introduces long-wearing nylon fabrics in *all* car series. It gives you the same kind of richness, softness and plushness found only on the most expensive American and European automobiles. What's more, Ford now brings you an all-new trim of "radiant" vinyl that gives the interior a brighter, more spacious effect. Because this vinyl is less porous, dirt cannot penetrate easily and it is far easier to clean!

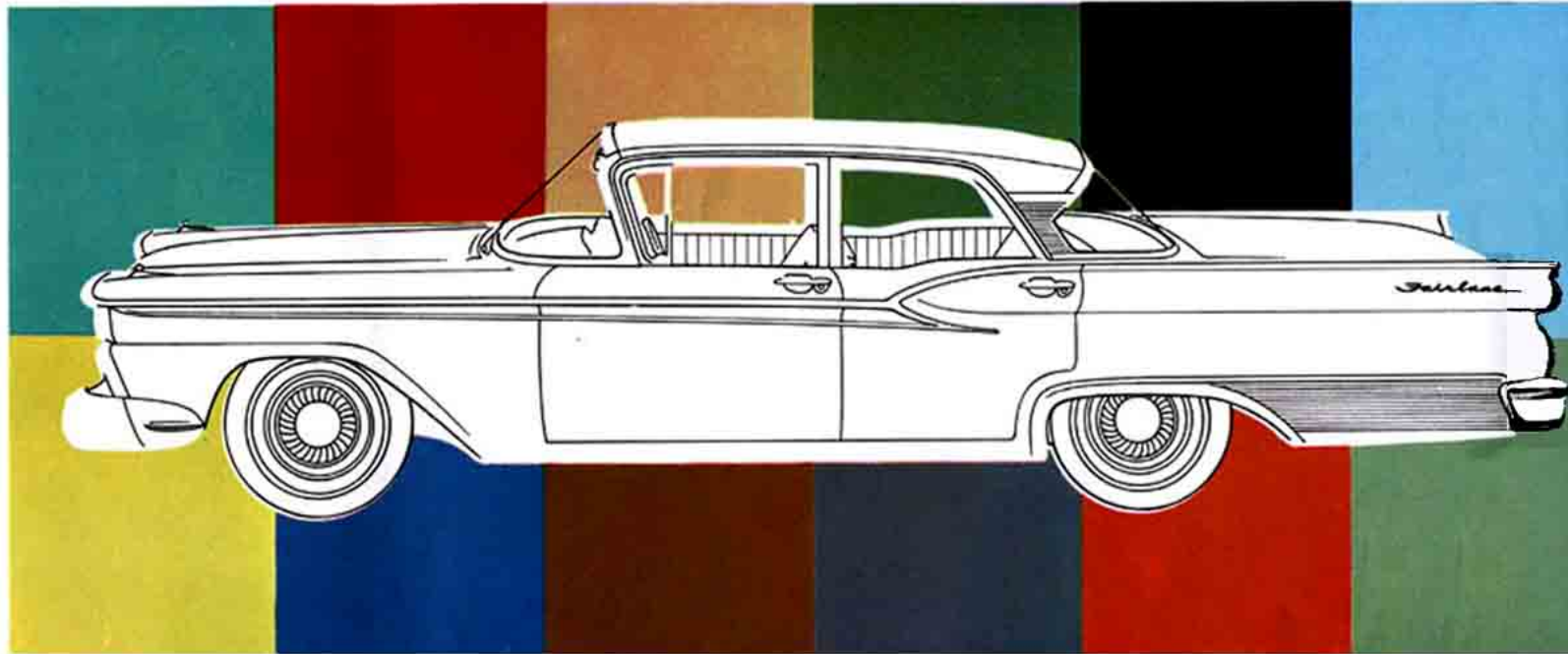

STYLE-TONE COLOR COMBINATION



CONVENTIONAL TWO-TONE COLOR COMBINATION



SINGLE COLOR

300-hp Thunderbird 352 Special V-8

Here is the *newest* version of Ford's famous Thunderbird V-8 engine! This 4-barrel V-8 is designed to give you a responsive surge of lively power in the speeds where you do most of your driving: between 30 and 70 miles per hour. This is power you can use . . . not unneeded power at the upper end of the speed curve! And for "built-in" overdrive economy, just team it with Cruise-O-Matic Drive!

225-hp Thunderbird Special 332 V-8

For 1959 Ford engineers have equipped this engine with a 2-venturi carburetor that has new jets for improved fuel economy. Team it with Cruise-O-Matic or new, low-cost Fordomatic Drive and you'll make fewer stops for gas! Also, new super-fitted aluminum-alloy pistons have longer skirts for better oil control. This engine gives you power as you like it . . . where you can use it!

200-hp Thunderbird 292 V-8

Now you can actually enjoy Thunderbird V-8 power at surprisingly *low* cost! This standard Ford V-8, like all Ford engines for '59, has new wedge-shaped combustion chambers for better gas-saving performance . . . plus Ford's deep-block, overhead-valve, short-stroke design. And it is designed to thrive on *regular* gasoline. Saves you money on every gallon!

145-hp Mileage Maker Six

This lively Six is the *only* modern 6-cylinder engine offered today. In the last two Mobilgas Economy Runs, its low-friction, short-stroke design was responsible for powering a Ford to the most actual miles per gallon of any car in Class A! What's more, it thrives on *regular* gas. You save up to 5¢ on every gallon compared with premium!

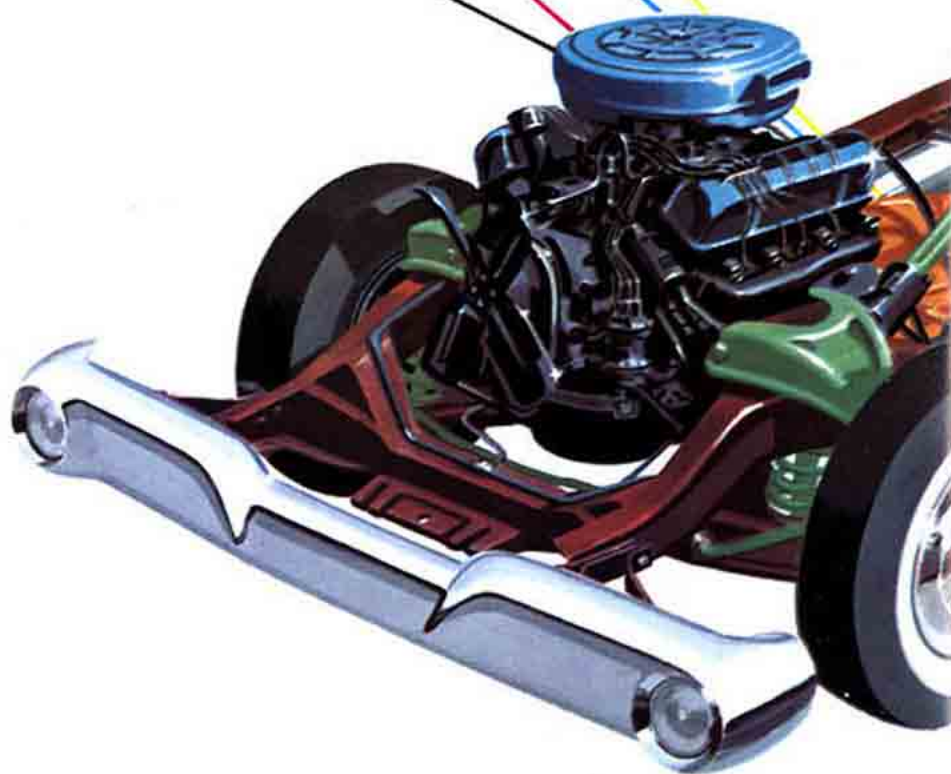
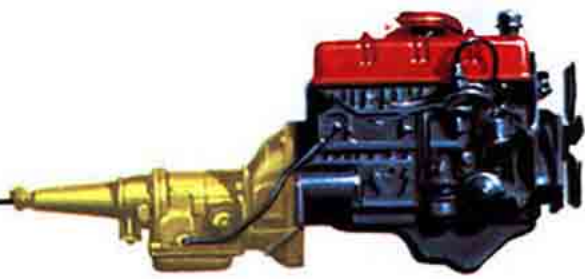

NEW POWER . . . WHERE YOU CAN USE IT!

There's a big difference in Ford's Thunderbird V-8 engines for '59. They give you more responsive power in the legal driving limits between 30 and 70 miles per hour where you can use it . . . rather than at top speeds where you never need it! These powerful engines represent the *best* in power plants from the world's master engine builder—Ford. Nobody builds so much rugged dependability into an engine.

As for economy, all Ford engines include a Full-Flow oil filter as *standard* equipment. You need change oil only each 4000 miles instead of the 1000 often recommended. And, there's a vacuum-booster type fuel pump for safer, more positive windshield-wiper operation.

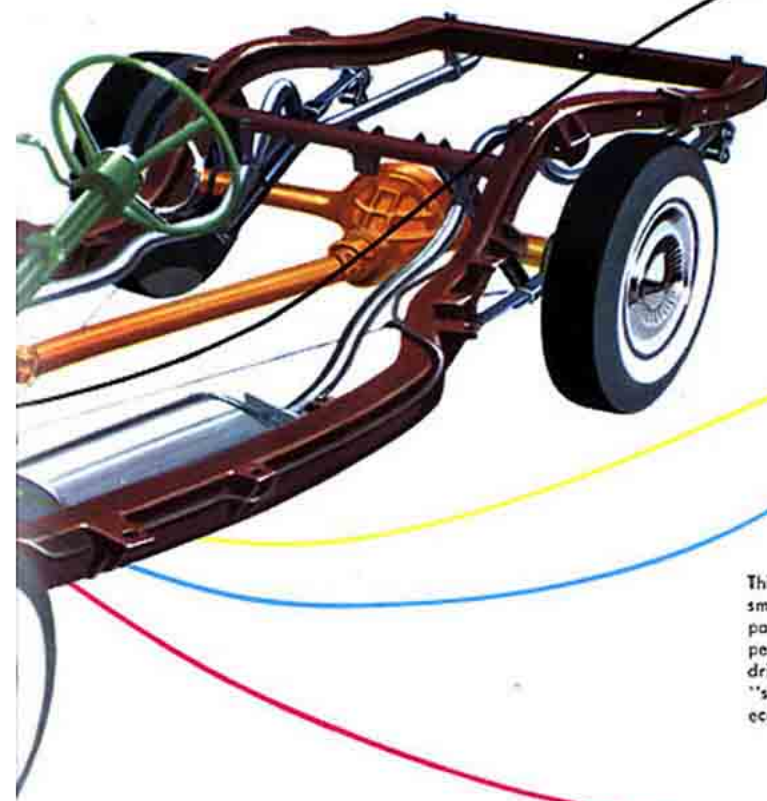

RUGGED CHASSIS . . . NEW FROM TYREX CORD TIRES UP

Here is the safest, most-tested chassis ever designed by Ford, the car that pioneered famous Lifeguard Design. Observe how Ford's husky frame bows out a full foot *wider* midway to give you far greater protection than other cars in the event of side impact!

All tires on Ford's '59 chassis are made of new *Tyrex* cord, the super cord that is the talk of the tire industry. The front suspension has a new link-type, rubber-bushed ride stabilizer. Team this with Ford's *variable-rate* rear suspension and you have complete Automatic Ride Control!

TRANSMISSIONS

CONVENTIONAL DRIVE

Here is the *easiest, quietest* manual shifting ever developed! To give you the utmost in economy, gear ratios are tailored to each engine. A lively performer!



FORDOMATIC DRIVE

This new, simplified automatic performs with satin smoothness. Lighter in weight with nearly $\frac{1}{3}$ fewer parts, its more durable design normally needs no periodic service. It brings the benefits of *shiftless* driving at a price so realistic that it should banish "stick shifting" forever! And for the ultimate in gas economy, just team it with a Mileage Maker Six!



OVERDRIVE

Saves on gas while it saves your engine! Automatic 4th gear lets your engine loaf at 35 mph while you actually travel 50 mph. Saves up to 15% on fuel bills, too!



CRUISE-O-MATIC DRIVE

You enjoy "built-in" overdrive economy from a gas-saving rear axle with Cruise-O-Matic! It gives you two separate driving ranges: "D1" for all normal driving, delivers brisk, solid-feeling starts in low and smooth acceleration right up to superhighway cruising speeds . . . "D2" for gentle, sure-footed starts in intermediate, when you're on ice, snow or loose gravel.

PICK YOUR OWN POWER TEAM!

ENGINE*	TRANSMISSION
145-hp Mileage Maker Six	3-Speed, Overdrive or Fordomatic
200-hp Thunderbird 292 V-8	3-Speed, Overdrive or Fordomatic
225-hp Thunderbird 332 V-8	Fordomatic or Cruise-O-Matic
300-hp Thunderbird 352 V-8	3-Speed, Overdrive, Fordomatic or Cruise-O-Matic

*All engines available in all models except Skyliner comes with V-8 only.

New convenience! A foot-operated parking brake—a luxury feature usually found only on expensive cars—is standard equipment on every '59 Ford! Brake may be set at various "on" positions; releases by a hand-operated release lever.

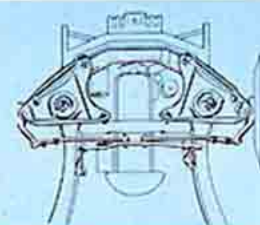

Exclusively Ford is the swept-back angle-poised ball-joint front suspension that now features a new link-type ride stabilizer. Helps your Ford give you a smooth, limousine-like ride!

Even-Keel rear springs are mounted outside the frame to cushion your ride for better . . . let you take the turns much steadier. And shock absorbers have been revolved to give for less ride motion.

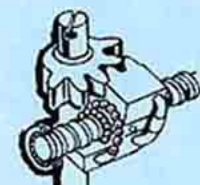
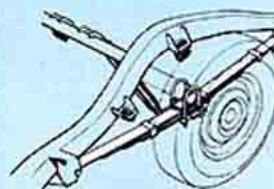

Ford's Magic-Circle steering is the closest thing yet to power steering! The steering wheel turns on free-rolling steel ball instead of the conventional worm gear. This efficient design gives you easier turning and smoother over-all handling!

Deep-offset hypoid rear axle with straddle-mounted pinion allows larger gear teeth to be used on both ring and pinion gears. This permits lower drive line positioning; boosts efficiency.

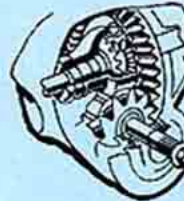

Ford brakes are double sealed to help you stop in all weather. They feature a fixed anchor design that requires only a simple single-point adjustment. All brake linings are riveted and have 180 square inches lining area (191 on Skyliner) for longer life.

New aluminized muffler will normally last twice as long as conventional mufflers used on other cars. The 3-ply design for V-8's (shown), with asbestos interlining, has high resistance to condensation and corrosion.

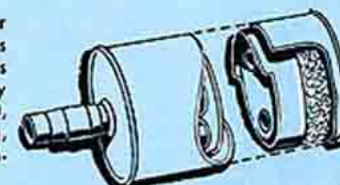

Power-Lift Windows are just one of the luxuries that Ford puts at your finger tips as an optional feature for '59. Just touch the central control buttons on the driver's door and you can raise or lower any window. For passenger's convenience, there's a handy button under each window, too.

Power Front Seat. Touch a button and your seat automatically goes forward, backward, up or down. It is an infinite position, posture-control seat with synchronized tilting back.

Master-Guide Power Steering has been improved further to cut your parking effort up to 85% and assist you in all your driving. Yet you retain the "feel of the road" wherever you drive.

Swift Sure Power Brakes with a low pedal are the brakes you love to touch. Stopping takes up to 1/3 less effort. Makes driving in traffic much easier, more relaxing. It's just touch and "whoa!"

GENUINE FORD OPTIONS AND ACCESSORIES FOR 1959

DeLuxe Rear Deck Antenna with new styled base

Rear Seat Speaker with 3-way control

Sure-Wipe Electric Wipers give positive 2-speed operation

Aquamatic Windshield Washer-Wiper works at touch of your toe

Flying Ellipse Hood Ornament

Bright-Metal "Eyebrow" Molding for front fender

Cushion-Stop Bumper Guards (front or rear) are bomb-shaped with rubber tips

Front Bumper Extensions of bright-metal

Sun-Ray Wheel Covers—standard on Fairlane 500's; optional on other models (shown with extra-cost center dress-up kit)

DeLuxe Rearview Mirror with ultra-smart styling in a full-visor design

Ribbed Bright-Metal Body Molding for Fairlane models

Beauty Guard Fender Shields stainless steel or painted

Sport Spare Wheel Carrier

Flying Dart rear quarter panel ornamentation, plus new Tee Ball Fender Ornaments, combine to make up an exterior trim option package for Custom 300 models.

Exhaust Deflectors are bumper-mounted, chrome-plated

Wheel Cover Dress-Up Kit for Sun-Ray wheel covers (shown in center of spare wheel carrier)

Backup Lights are made operational by addition of bulbs and wiring

Set your family
2-FORD FREE

Look at these other beautifully proportioned new Fords for '59—headed by the fabulous 4-passenger Thunderbird! You can team up almost any one of these beauties with your new Ford and still pay no more than you would for one expensive car! But what a difference in family freedom! Select the best two-Ford combination for your family now. You'll find they're all priced Ford-low!

THUNDERBIRD HARDTOP

THUNDERBIRD CONVERTIBLE

9-PASSENGER COUNTRY SQUIRE

9-PASSENGER COUNTRY SEDAN

FORDOR COUNTRY SEDAN

COUNTRY SEDAN

FORDOR RANCH WAGON

RANCH WAGON

SAFETY Since Ford pioneered Lifeguard Design three years ago, Ford safety features have proven thousands of times that they *do* save lives. For '59 Ford offers:

a Lifeguard sun visors: full-cushioned with super shock-absorbing material.*

b Lifeguard safety-swivel rearview mirror: swings away if struck.

c Seat belts: help keep you in your seat in case of impact.*

d Lifeguard door locks: give added protection against doors springing open upon impact.

e Lifeguard cushioning: provides vital protection on instrument panel.*

f Lifeguard Jr. safety locks help prevent "small fry" (and adults) from accidentally opening a rear door.*

g Lifeguard deep-center steering wheel: protects driver from the steering post.

h Lifeguard arm rests: fully cushioned with shock-absorbing material.

Other fine Ford options and accessories at your Ford Dealer's

Signal Seek Radio* automatically tunes in station in either direction of the dial. Town button (T) tunes local stations, Country (C) gives broad coverage.
*Transistor-powered.

Console Range Radio is transistor-powered for '59, yet is still moderately priced. Automatic push-button tuning gives you a choice of any five preselected stations.

MagicAir Heater is of all-new "magic-blend" design. It blends desired amount of cool with fresh hot air. Not only does it heat more quickly, but its new thermostatic control will give you the temperature you want—instantly!

Self-regulating electric clock* re-times itself automatically each time you set it! The smart functional design is accentuated by illuminated dial and full-sweep second hand.
*Standard on Fairlane 500.

PolarAir Conditioner offers cool comfort at surprisingly low cost (V-8's only). Its "on-off" magnetic clutch controls car temperature automatically.

SelectAir Conditioner has large compressor and strategic placement of air registers. You get refrigerated cooling, ventilating, heating and defrosting in one compact unit. (V-8's only)

New Inside Non-Glare Mirror is ten inches wide; turns off blinding glare from headlights behind with a touch of your finger.

Adjust-O-Ring Mirror gives you a wide range of adjustment. Its ring visor provides protection against rain, snow and mud.

Visored Spotlight Mirror gives night-and-day convenience. And the hooded feature makes it effective in all weather. Adjusts easily from inside car.

4-WAY MANUAL TILT FRONT SEAT
FULL TONE MANUAL RADIO
RECIRCULATING HEATER & DEFROSTER
1-RST TINTED GLASS
INTERIOR TRIM PACKAGE (Custom 300)
SOUND DEADENER PACKAGE
CURB-GUARD BODY MOLDING (Fairlane 500)
FULL-VIEW MIRROR
VISORED FULL-VIEW MIRROR
FRONT LICENSE PLATE GUARD
LICENSE PLATE FRAMES
DELTA-WING EXHAUST DEFLECTORS
EQUA-LOCK DIFFERENTIAL
PARKING BRAKE SIGNAL
REAR DECK RELEASE (at driver's seat)
VANITY MIRROR
TISSUE DISPENSER
LITTER BAG
LOCKING GAS CAP
FLOOR MATS, CONTOUR (Front, Rear and Twin Front)
VENTILATED SEAT CUSHIONS
SEAT COVERS

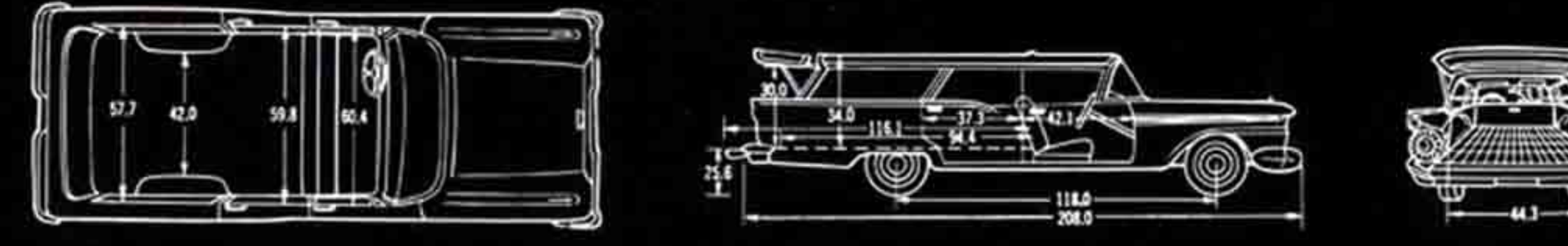

SPECIFICATIONS

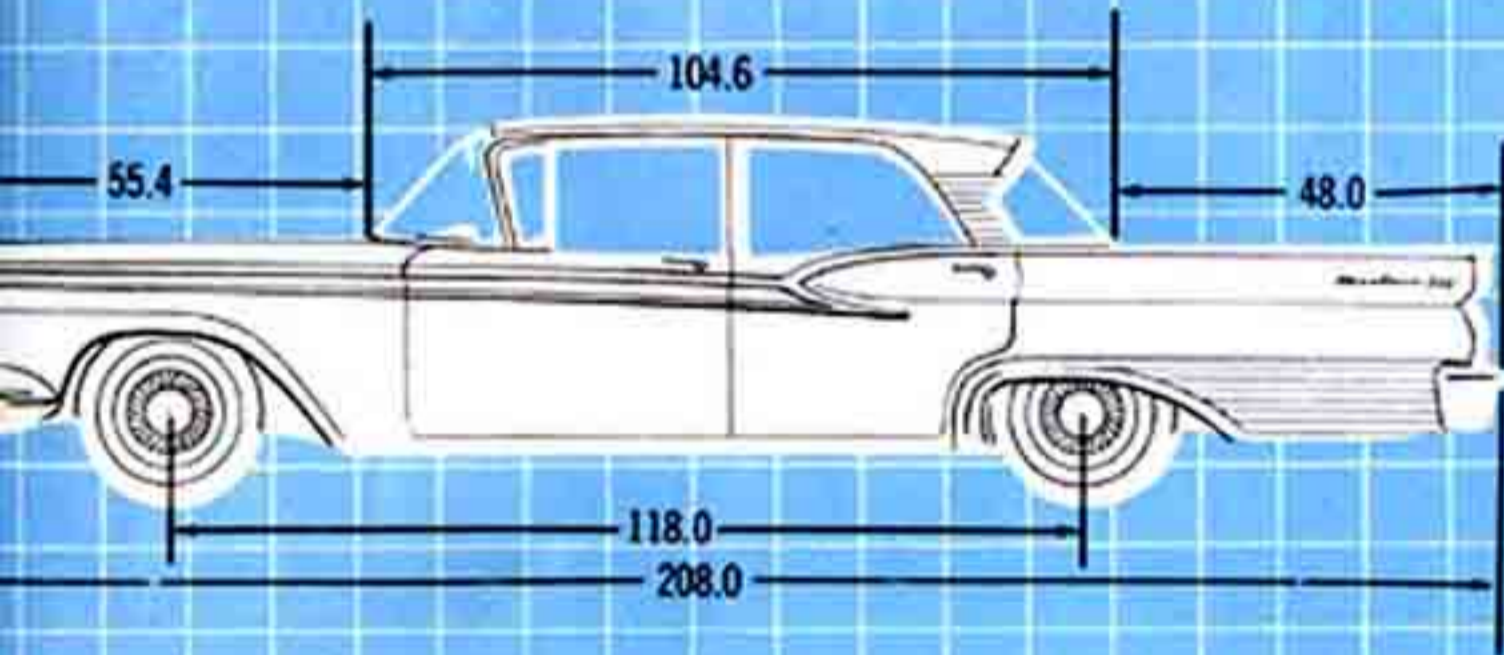
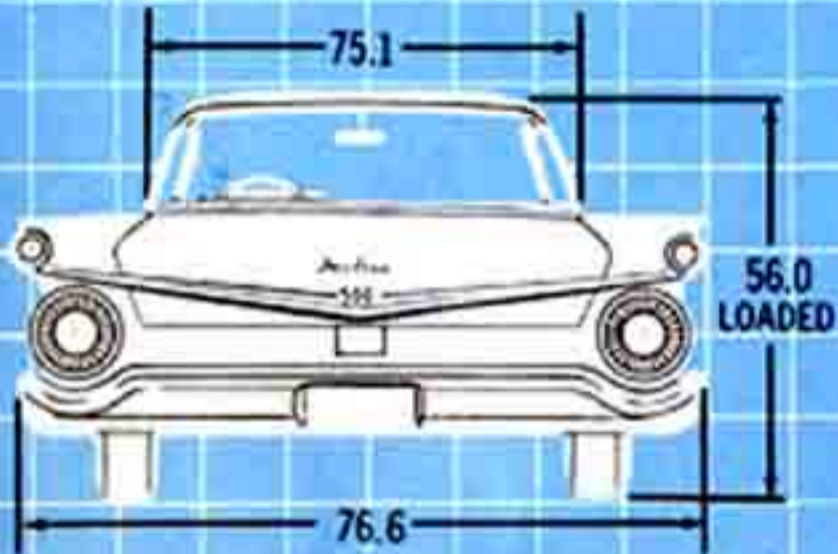
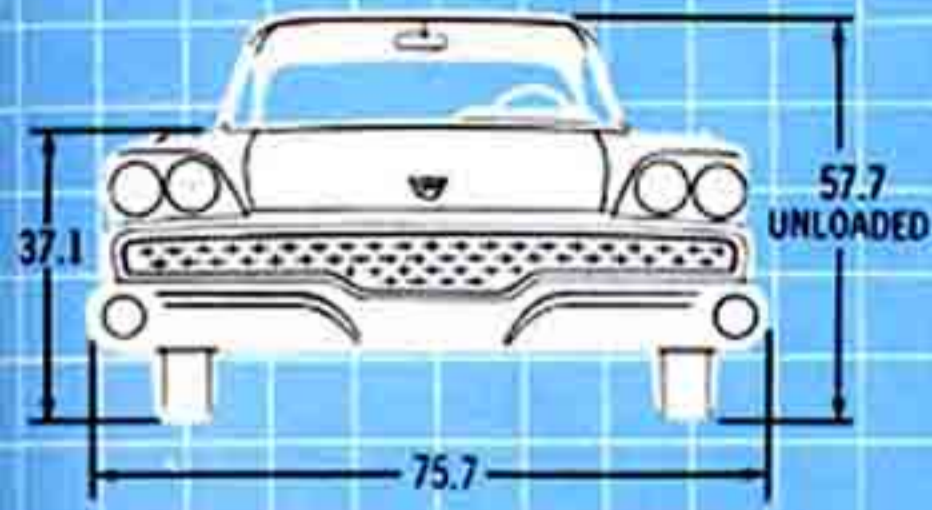

Exteriors: Amazing new Diamond Lustre Finish, most durable body finish ever developed, is available in Single Color, Conventional Two Tone or Style Tone selections.

Basic colors are Raven Black, Gunsmoke Gray, Colonial White, Surf Blue, Wedgewood Blue, Sherwood Green, April Green, Tahitian Bronze, Fawn Tan and Torch Red for all series, plus Inca Gold for Fairlanes and Inca Gold, Geranium and Indian Turquoise for Fairlane 500's.

Interiors: This year Ford introduces long-wearing nylon fabrics in all car series. Another Ford "first" is the use of an all-new Radiant Sof-Textured vinyl trim. This new vinyl has a super-high-metallic coating that gives the interior a brighter, more spacious effect. Floor covering in Custom 300 models is Sof-Tred carpet-textured black rubber. Fairlane models have color-keyed Vinyl-Tex, which looks like carpeting, wears like vinyl. Fairlane 500 models (including the Sunliner convertible) have color-coordinated deep-loop luxury-loom carpets.

See the complete selection of colors and fabrics at your Ford Dealer's.

Engines: 145-hp Mileage Maker Six—223-cu. in. displ.; 3.62" bore x 3.60" stroke, 8.4 to 1 comp. ratio; regular fuel; manual choke. (For all models except Skyliner.)

200-hp Thunderbird 292 V-8 (Standard V-8 on all models)—292-cu. in. displ.; 3.75" bore x 3.30" stroke; 8.8 to 1 comp. ratio; regular fuel; low-silhouette 2-venturi carburetor, automatic choke, Y-type single exhaust.

225-hp Thunderbird 332 Special V-8 (Optional on all models)—332-cu. in. displ.; 4.00" bore x 3.30" stroke; 8.9 to 1 comp. ratio; premium fuel; low-silhouette 2-venturi carburetor, automatic choke, Y-type single exhaust [dual exhausts on Skyliner and Sunliner].

300-hp Thunderbird 352 Special V-8 (Optional on all models)—352-cu. in. displ.; 4.00" bore x 3.50" stroke; 9.6 to 1 comp. ratio; premium fuel; low-silhouette 4-venturi carburetor, automatic choke, dual exhausts.

Engine Features: For greater economy and longer life, all Ford engines have Short Stroke, low-friction design, with Deep-Block construction; intake and exhaust valves are free-turning, overhead type; Super-Filter air cleaner has reusable paper element; vacuum-booster fuel pump for positive windshield wiper action; lubrication is full-pressure type with Full-Flow disposable-type oil filter; 12-volt electrical system gives better starting ability; Turbo-Action 18-mm. spark plugs are designed for increased gas mileage; exhaust system features new aluminized muffler. V-8 engines are electronically balanced while operating under their own power for extra smoothness. Thunderbird Special V-8's feature self-adjusting, hydraulic valve lifters for quietness and Precision Fuel Induction for superior performance and economy.

Fordomatic Drive: All new for '59, Fordomatic uses a single-stage, 3-element torque converter and a compound planetary gear set. These are incorporated into an automatic mechanism that requires only one clutch assembly to provide two "forward" gear ratios . . . low and direct . . . and reverse. In "D" range it provides brisk, smooth starts in low. This simplified design uses 27% fewer parts and with its cast-aluminum construction is much lighter in weight. This new Fordomatic is so dependable that no normal servicing is required after initial 1000-mile band adjustment. Available with all engines.

Cruise-O-Matic Drive: A high performance automatic featuring two selective drive ranges—smooth 3-speed operation in "D1" range, starting in low for solid, full-power getaways and all normal driving . . . or smoother 2-speed operation in "D2" range, starting in intermediate for gentle, sure-footed acceleration on ice, snow or loose gravel. Coupled with specially tailored gas-saving rear axle ratios, it provides "built-in" overdrive economy. Available with Thunderbird Special V-8's only.

Wide-Contoured Frame: Strong, stiff, box-section frame. Skyliner and Sunliner have 4 cross members plus X-member; others have 5 cross members. Side rails extend outside passenger area, for better foot room and increased side protection. Silent-Grip body mounting system.

Suspension: Swept-Back Angle-Poised Ball-Joint front suspension has threaded, permanently lubricated bushings in upper control arms for soft, easy ride. Front end of all models has new link-type, rubber-bushed ride stabilizer to control roll on turns. Even-Keel rear springs provide soft action, variable rate with tension-type shackles and wind-up control rubber bumpers over springs. Viscous-control shock absorbers front and rear, give complete ride control.

Rear Axle: Husky, low-slung hypoid, semi-floating, with special Deep-Offset straddle-mounted pinion, permits lower car level without sacrifice of inside room.

Torque-Tailored Axle Ratios (to 1): Skyliner: Conventional Drive or Overdrive—3.89 with Six or 292 V-8, 3.70 with 352 Special V-8. **Fordomatic Drive—**3.56 with Six or 292 V-8, 3.10 with 332 Special V-8, 2.91 with 352 Special V-8. **Cruise-O-Matic Drive—**2.91 with 332 Special V-8, 2.69 with 352 Special V-8.

Optional Equi-Lock Differential Ratios (to 1): 3.70 with Six or 292 V-8 and 3-speed, Overdrive or Fordomatic, also with 352 Special V-8 and 3-speed or Overdrive; 3.10 with 332 or 352 Special V-8's and Fordomatic or Cruise-O-Matic.

All Other Models: Conventional Drive—3.56 (std.) or 3.70 (opt.) with Six; 3.56 with 292 V-8 or 352 Special V-8. **Overdrive—**3.70 with Six or 292 V-8, 3.56 with 352 Special V-8. **Fordomatic Drive—**3.56 with Six, 3.10 with 292 V-8, 2.91 with 332 or 352 Special V-8's. **Cruise-O-Matic Drive—**2.91 with 332 Special V-8, 2.69 with 352 Special V-8.

Optional Equi-Lock Differential Ratios (to 1): 3.70 with Six, 292 V-8 or 352 Special V-8 and 3-speed or Overdrive, also Six and Fordomatic; 3.10 with 292 V-8, 332 or 352 Special V-8's and Fordomatic, also 332 or 352 Special V-8's and Cruise-O-Matic.

Steering: Magic-Circle recirculating-ball type steering gear provides low friction, easy steering, 27 to 1 over-all steering ratio, 17½", 3-spoke, deep-center Lifeguard steering wheel. Approximately 40-foot turning diameter.

Brakes: Giant-Grip double-sealed, self-energizing hydraulic brakes have suspended pedal, dash-mounted master cylinder. Drum diameter is 11". Lining area is 180 sq. in. (191 sq. in. on Skyliner). Optional Swift Sure power brakes have special low pedal and power reserve tank.

Tires: 4-ply black tubeless tires of new Tyrex super cord on safety-type rims, standard on all models. Skyliner—8.00 x 14 on 5½" rims. Sunliner with V-8 and automatic transmission—8.00 x 14 on 5" rims. All others—7.50 x 14 on 5" rims.

Dimensions: 118" wheelbase on all models; 59.0" front, 56.4" rear treads. Over-all length, 208.0" (Skyliner 208.1"). Height (maximum with design load) 56.3" for Skyliner, 56.5" for Sunliner, 56.0" for all other cars. For other dimensions, see illustrations at left.

Other Available Equipment: Power front seat, Swift Sure power brakes, Master-Guide power steering, Power-Lift windows (except Business Sedan), Overdrive, Fordomatic, Cruise-O-Matic. White sidewall tires.

Prices: All Power Assists, Optional Equipment and Accessories as well as some of the items illustrated or referred to in this catalog are at extra cost. For the price of the model with the equipment you desire, see your Ford Dealer.

Comparative information in this catalog was obtained from authoritative sources, but is not guaranteed. The specifications contained herein were in effect at the time this catalog was approved for printing. Ford Division of Ford Motor Company reserves the right to discontinue models at any time, or change specifications or design without notice and without incurring obligation.

Compliments of

Your
Friendly
Ford
Dealer