

1983 OLDSMOBILE

AT HOME ANYWHERE IN AMERICA... AT HOME ANYWHERE YOU ARE.

CUTLASS CIERA • CUTLASS SUPREME • CUTLASS CRUISER



1983 OLDSMOBILE

No matter where you live in America. No matter who you are or what your lifestyle, there's a 1983 Oldsmobile that fits right in.

Oldsmobile has long recognized that there is no such thing as a "typical American driver." America's drivers are as diverse as America itself.

It's horizontal-stretching highways in the Texas Panhandle, hairpin curves in the Colorado Rockies. It's Yuma, Arizona, with 110° in the shade and Bangor, Maine, at 10° below. It's small towns, pleasant suburbs and bustling cities, seashores, mountains and forests.

So Oldsmobile recognizes that it's not only who you are, but where you live and how you drive that has a lot to do with choosing the car that's right for you. That's why Oldsmobile offers such a wide variety of models for 1983—30 models which differ in size, style and driving appeal.

You can choose from economical small cars and compacts like Firenza and Omega... stylish intermediates like Cutlass Supreme and Cutlass Ciera... roomy family-size Delta 88... and the luxurious Ninety-Eight Regency and one-

of-a-kind Toronado. But there's more. Would you like to have front-wheel drive? You can. Rear-wheel drive? You can. Gasoline or available choices are many. And what you want or imagine. What it matters who you are, where you live or what you like doing, there's a 1983 Oldsmobile



of-a-kind Toronado. You can. Rear-wheel drive? You can. Gasoline or available choices are many. And what you want or imagine. What it matters who you are, where you live or what you like doing, there's a 1983 Oldsmobile that's built for you.

Oldsmobile

Have one built for you.

LUXURY-SIZE AND FAMILY-SIZE OLDSMOBILES:



TORONADO

One-of-a-kind car in a carbon-copy world.



NINETY-EIGHT REGENCY

The luxury car for logical people.



DELTA 88

The family car that didn't forget the family.

AMERICA'S FAVORITE MID-SIZE OLDSMOBILES:



CUTLASS SUPREME

An American favorite in style and value.



CUTLASS CIERA

The best that is Cutlass... plus front-wheel drive.



CUTLASS CRUISER

First it's an Oldsmobile. Then, it's a wagon.

SMALL CARS WITH BIG OLDS IDEAS ABOUT VALUE:



OMEGA

Compact car practicality with solid Olds value.



FIRENZA

What a small car can be when it's an Oldsmobile.



FIRENZA CRUISER

Versatile new wagon joins the Firenza line.

Important: A word about this catalog. We have tried to make this catalog as comprehensive and factual as possible and we hope you find it helpful. However, since the time of printing, some of the information you will find here may have been updated. Also, some of the equipment shown or described throughout this Olds catalog is available at extra cost. Your dealer has details and, before ordering, you should ask him to bring you up-to-date. The right is reserved to make changes at any time, without notice, in prices, colors, materials, equipment, specifications and models. Check with your Olds dealer for complete information.

A word about engines: Some Oldsmobiles are equipped with engines produced by other GM divisions, subsidiaries or affiliated companies worldwide. See your dealer for details. Please refer to the "Fuel Economy Estimate/Engine Supplement Sheet" provided to your dealer for engine source and EPA mileage estimates.

CUTLASS CIERA BROUGHAM SEDAN

A new style and elegance of its own. A careful attention to quality and detail. It's a tasteful experience that has you feeling right at home.



CUTLASS CIERA BROUGHAM

Brougham luxury in the first front-wheel-drive Cutlass. At Oldsmobile, we believe that a front-wheel-drive car should do a lot more than take to the road. It should hold your attention.

It should hold your attention with elegance that surrounds you. With seats that are full-foam, deep and comfortable. With rich knit velour fabrics,

that are soft and luxurious to the touch.

Outside, Cutlass Ciera Brougham holds your attention with a clean, aerodynamically efficient shape—tested in a wind tunnel, and bred for the open road. It can slip through the wind as easily as it slips past gas stations. It offers impressive EPA mileage estimates—with standard 2.5-liter L4

engine and electronic fuel injection or available 3.0-liter V6. For top Cutlass Ciera economy, a 4.3-liter diesel V6 is available.

Cutlass Ciera can hold your attention with quality. It is a product of modern technology.

It will hold your attention with built-in value, too. Power steering, power front disc brakes, automatic

transmission, side window defoggers, full-wheel covers, deluxe steering wheel, headlamp-on reminder, even a quality Delco AM radio (can be deleted for credit) and more—all standard.

From maneuvering the road to holding your attention, the stylish front-wheel-drive Cutlass Ciera can do a whole lot more than just hold its own.



CUTLASS CIERA BROUGHAM COUPE

Great lines and a solid supporting cast brought together with careful direction. This road show has you feeling right at home.



CUTLASS CIERA LS SEDAN

Let others settle for copies. You feel more comfortably at home—with an original. Sure, there are a lot of front-wheel-drive cars around today. But only one is an Oldsmobile Cutlass! In the LS Sedan that means family-size room and four-door convenience. It also means a custom-sport seat in rich velour, with center armrest and convenience tray, standard. Cutlass Ciera LS Sedan. It's a Cutlass original you can value for a long, long time.



CUTLASS CIERA LS COUPE

Fit and trim. A new look and style that are right at home for the long run. The front-wheel-drive Cutlass Ciera LS Coupe is every bit as agile as it is beautiful. And it is meant to go the distance. It has been designed and built with the benefits of modern automotive technology.

See your Olds dealer and take a Cutlass Ciera LS Coupe out for a few laps. *NOTE: Early 1983 Cutlass Ciera Coupe models will feature the same side window pillar as 1982 models. Not the wide pillars as shown on pages 3, 8, 11 and 13.*



CUTLASS CIERA ES SEDAN

Grab a handful of sport wheel, slip the automatic to drive, and give the fuel injection the right of way. Excitement by ES, where you're right at home. The available ES package quickens the pulse as easily as it turns heads. Black grille and moldings add sophistication, while those styled wheel discs add distinction. Special suspension, custom sport steering wheel, sport console with shifter, full instrumentation and more—all included.



CUTLASS CIERA ES COUPE

A fresh look and invigorating spirit. An adventurous attitude that has you feeling right at home. Behind the wheel, that's where you discover the real thing. Do it. Settle into the reclining front bucket seat. And move out—with fuel-injected spirit and special suspension, standard. Distinctive black grille, styled sport wheels, custom sport steering wheel, sport console with shifter and more—all part of the available ES package that helps whisk you away from the ordinary.



Cutlass Ciera facts, figures and features.



Cutlass Ciera instrument panel. Impressive instrumentation at your finger tips.

See all that luggage? It will rest nicely in the Cutlass Ciera trunk.



New patch rearview mirror. Sleek, stylish.



Consoles available. One with shift lever. One with extra storage space for cassette tapes.

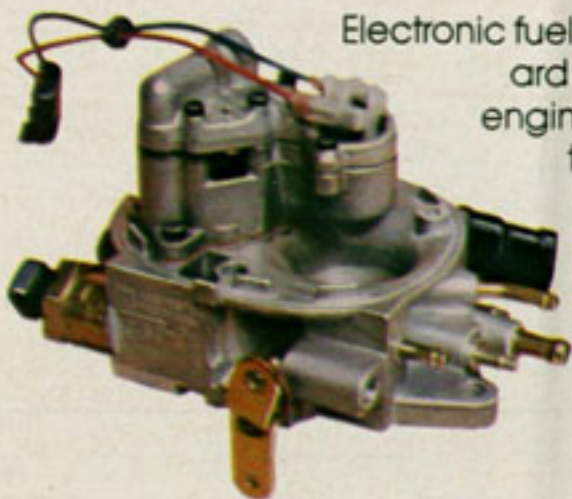

Electronic fuel injection. Standard on the 2.5-liter L4 engine. Provides electronically precise metering of air and fuel for impressive mileage.*



Wheel trim. (A) Deluxe-wheel discs are standard. Available: (B) Wire wheel discs with locks, (C) Super Stock wheels and (D) Deluxe styled wheel discs (ES Models only).

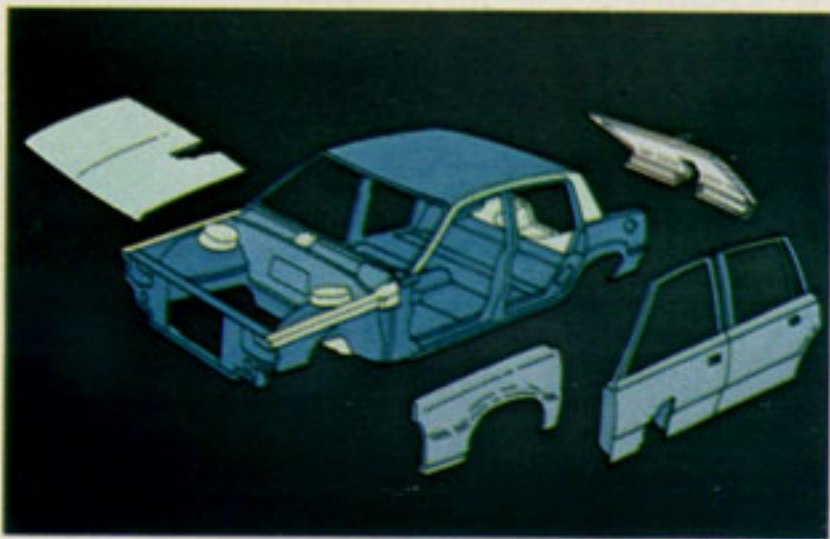

Extensive anti-corrosion measures. Includes galvanized metals, plastisols, sealers, front fender liners, waxes and zinc-rich primers.

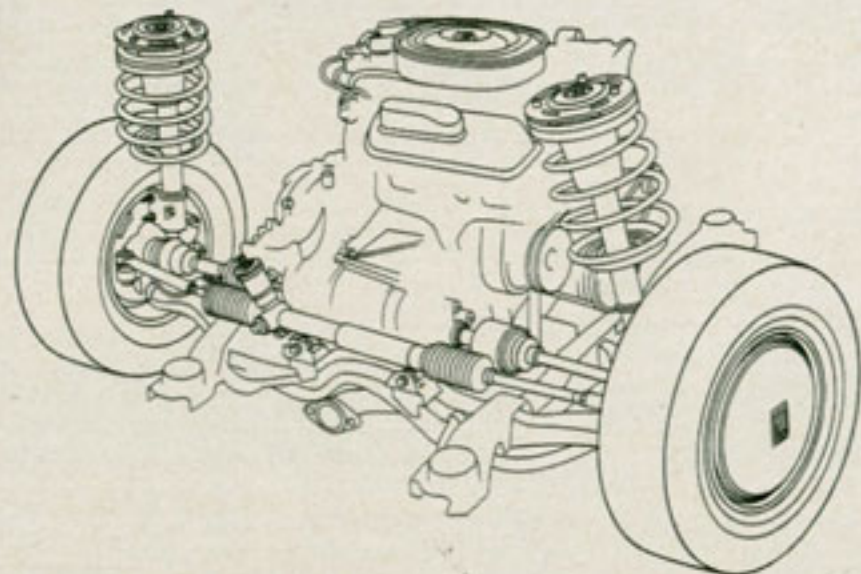

Front-wheel drive puts the engine weight over the wheels that power and steer you for impressive traction. MacPherson strut suspension adds to Cutlass Ciera's smooth, quiet ride.



New electronic instrument panel cluster available. Includes digital speedometer, bar graph fuel level and engine temperature gages, low fuel warning indicator, trip odometer, English/metric conversion switch, plus turn signal indicators. (Not available at announcement).



New trunk top luggage rack available. For the extra carrying space you might need. Stylish, too.



Reclining front seat backs for driver or passenger side. With bucket seats—available in coupes only (passenger side).

CUTLASS CIERA STANDARD EQUIPMENT

Chassis and Body:
 ■ Computer Command Control ■ Electronic Fuel Injection ■ High-Energy Ignition System ■ Power Rack-and-Pinion Steering ■ Low-Drag Power Front Disc Brakes ■ MacPherson Strut Front Suspension ■ Front and Rear Bumper Fascia Covers ■ Bright Roof Drip and Belt Reveal Moldings ■ Extensive Anti-Corrosion Treatments ■ Space-Efficient, Full-Width, Flat Trunk Space ■ Compact Spare Tire Hidden Beneath Floor ■ Maintenance-Free Battery ■ Delcotron ■ Automatic Transmission with Torque Converter Clutch ■ Easy-Roll Tires are Match-Mounted to Each Wheel ■ Dual Fluidic Action Windshield Washer System ■ Patch-Style Outside Mirror ■ Deluxe Wheel Discs

Interior:

■ Full-Foam Seat Construction, Front and Rear ■ Armrest, Front and Rear ■ Simulated Butterfly Walnut Grain Instrument Panel Accents ■ Side Window Defogger ■ Interior Operated Hood Lock Release ■ Headlamp-On Warning ■ Cigar Lighter ■ Inside Day/Night Rearview Mirror ■ Deluxe Seat Belts Color-Matched to Individual Interiors ■ Flo-Thru Ventilation System ■ Deluxe Steering Wheel ■ AM Pushbutton Radio with Dual Front Speakers and Fixed Mast Fender Antenna (may be deleted for credit) ■ Cut Pile Carpeting, Wall-to-Wall with Carpeted Lower Door Panels ■ Automatic Front-Door Lamp Switches ■ Dome Lamp

STANDARD EQUIPMENT BY MODEL

Cutlass Ciera LS Coupe and Sedan:

■ Engine 2.5-liter L4, with Electronic Fuel Injection ■ Automatic Transmission ■ Custom Sport Bench Seat with Center Armrest ■ Cloth or Vinyl Trim ■ Interior Door-Pull Handles ■ Front-End Panel Stand-Up Ornament ■ Rocker Panel and Wheel-Opening Moldings ■ Specific Pillar Identification ■ Deluxe Wheel Discs ■ Tires P185/80R13 Glass-Belted Radial-Ply Blackwall

Cutlass Ciera Brougham Coupe and Sedan:

■ Engine 2.5-liter L4, with Electronic Fuel Injection

An inside look at the new Cutlass Ciera...

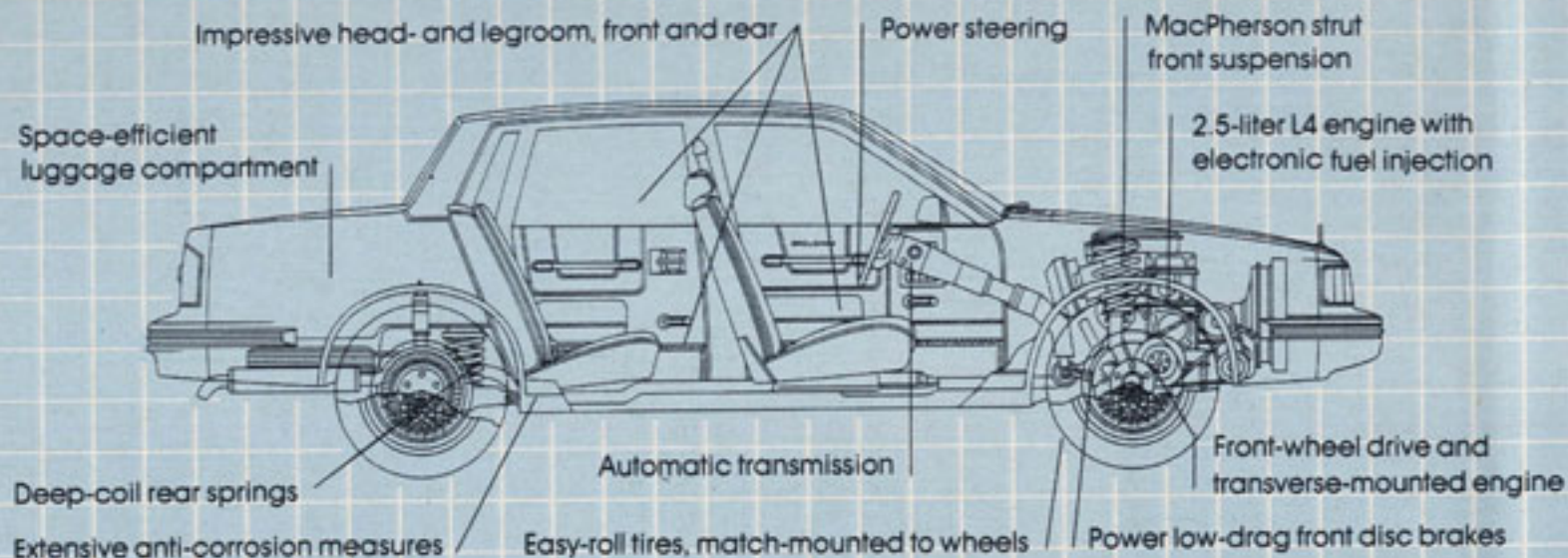

CIERA POWER TEAMS		LITER/TYPE		DIMENSIONS: (Coupe/Sedan)	
Standard Engine:*	4.3/V6 Diesel	188.4/188.4	(in.)	188.4	front (in.)
Liter/Type	2.5/L4 Carburetion	104.9/104.9	Wheelbase (in.)	104.9	rear (in.)
	Electronic Fuel Injection	15.8/15.8	Luggage Capacity (cu. ft.)	15.8	Shoulder Room, front (in.)
Available Engines:*	3.0/V6 Carburetion	15.7/15.7	Fuel Tank Capacity, Gasoline (gals.)	15.7	rear (in.)
	2-Barrel	17.0/17.0	Diesel (gals.)	17.0	Legroom, front (in.)
			Headroom,		rear (in.)

■ Automatic Transmission ■ Divided Front Seat with Individual Controls and Center Armrest ■ Knit Velour Trims ■ Bright Rocker Panel and Wheel-Opening Moldings, plus Wide Lower Moldings on Doors, Front Fenders and Rear Quarters ■ Specific Front-End Panel Stand-Up Ornament ■ Deluxe Wheel Discs ■ Tires, P185/80R13 Glass-Belted Radial-Ply Blackwall ■ Convenience Group, Lamps, Visor Vanity Mirror and Chime Tones

Available Ciera ES Package...

■ Blacked out Grille Bars, Headlamp Housings, Lower Deck Lid, Rear-End Panel, Bumper Rub Strips, Body Side Moldings ■ Bright Rocker Moldings ■ Dual-Outlet Muffler—Twin Tailpipes ■ Specific ES Emblems ■ Reclining Bucket Seats ■ Sport Console with Shifter ■ Firm Ride and Handling Package ■ Custom Sport Steering Wheel ■ Styled Wheel Discs ■ P195/70R14 Steel-Belted Radial-Ply Blackwall Tires ■ Rallye Instrument Panel Cluster...and much, much more

CUTLASS CIERA LS/CIERA BROUGHAM AVAILABLE EQUIPMENT:

6-Way Power Seat Adjuster (Bucket Seat, Driver Side)
 6-Way Power Seat Adjuster (Divided Seat, Driver Side, LS and Brougham)
 Removable Tempered Glass Sunroof

Reclining Seat Back, Passenger Side
 Power Door Locks
 Soft-Ray Tinted Glass
 Power Side Windows
 Power Trunk-Lid Lock Release
 Auxiliary Floor Mats, with Carpet Inserts
 Contour Reclining Front Bucket Seats
 Deluxe Luggage Compartment Trim
 Body Side Moldings, Color-Matched to Body, or Vinyl Rooftop
 Custom Sport Steering Wheel
 Tilt-Away Steering Wheel
 High-Capacity Battery System
 Instrument Panel Rallye Gages
 Bright Door-Edge Guards
 Landau Padded Vinyl Roof Covering (Coupe)

Full Vinyl Roof Covering
 Four-Season Air Conditioner
 Combination Dome and Reading Lamp
 Electric Rear Window Defogger
 Sport Console, with or w/o Shifter
 Cruise Control with Resume Feature
 Super Stock Wheels, Color-Matched to Body
 Wire Wheel Discs with Locks
 Puncture-Sealing Tires
 Tires, P185/80R13 Steel-Belted Radial-Ply Blackwall
 Tires, P185/80R13 Steel-Belted Radial-Ply White-Stripe
 Tires, P185/75R14 Steel-Belted Radial-Ply Blackwall or White-Stripe required and available only with diesel engine
 Pulse Windshield Wiper System
 Luggage Compartment Trim, Deluxe
 Body Side Accent Stripes
 Engine Block Heater
 Engine Block Heater, plus Fuel-Line Heater (Diesel only)
 Convenience Group, Lamps, Visor Vanity Mirror and Chime Tones (Std. on Brougham)
 Tungsten Halogen Headlamps (High-Beams)
 Deck Lid Luggage Carrier
 Ciera ES Package
 Two-Tone Paint Scheme
 Firm Ride and Handling Package
 Trailer Electrical Wiring Harness
 Automatic Leveling System
 High-Capacity Cooling Systems
 Radios and Tape Players (See Page 30)
 3.0-liter V6, 2-bbl. Engine
 4.3-liter Diesel V6 Engine
 Outside Mirrors—Remote and Manual Control, driver and passenger

*See EPA mileage estimates in accompanying Fuel Economy Estimate/Engine Supplement Sheet.

CUTLASS SUPREME BROUGHAM COUPE

Among contemporary classics of artistry in metal, it's right at home.



CUTLASS SUPREME BROUGHAM

Outside, a classic in metal artistry. Inside, the lap of Oldsmobile luxury. Deep-cushioned seats that comfort and support. Rich velour fabrics so soft to the touch. Elegant to be sure. But like every new Cutlass, Supreme Brougham is a total value car. And it's that total value that has helped Cutlass sell more cars over the last

eight years than anyone else.

You see value in Cutlass—in the fit and finish and attention to detail.

You feel it in the computer-selected coil spring ride, smooth and quiet.

You feel it in the handling as you maneuver deftly through busy city traffic.

But Cutlass value doesn't just happen. It's designed and built right in. Power steering, power front disc brakes, automatic transmission, deluxe steering wheel, deluxe wheel covers, steel-belted tires and more are all standard.

You'll like the value of the fuel efficiency, too—with standard 3.8-liter V6 or available 5.0-liter

V8. For even greater fuel economy, you can choose from two available diesel engines, a 4.3-liter V6 and 5.7-liter V8.

But the bottom line on value is how well a car holds its value. And that's where Cutlass Supreme is golden. Cutlass Supreme has had a traditionally high resale value year after year.



CUTLASS SUPREME BROUGHAM SEDAN

You're experiencing it all The tradition, the heritage, American ingenuity and pride. You're right at home.



CUTLASS SUPREME COUPE

The elegant lines. The carefully selected fabrics. It's right at home—a beautiful expression of your good taste. For all its elegance and good taste, Cutlass Supreme Coupe is the easiest way of all to enjoy the comfort, style, quality and solid value of a Cutlass Supreme. With a price that's as attractive as the car—you'll be right at home with the new Olds Cutlass Supreme. It's no wonder that it has become the most popular Oldsmobile—ever!



CUTLASS SUPREME SEDAN

Your quiet getaway. Comfortable and relaxing. Apart from the everyday. Yet so affordable you're right at home. With great Oldsmobile looks and sedan convenience, the new Cutlass Supreme Sedan is right in tune with today. Check out its solid value. And you'll find it's a nice surprise for people who think they can't afford Cutlass room, comfort and quality. In fact, with all its great looks, it's the lowest priced Cutlass Sedan of all.



CUTLASS CALAIS

The high country. Where everything fights to make it, there's one that makes it all look easy. It's right at home—in grand touring style. With Cutlass Calais, you don't just go through a curve. You have the distinct feeling you own it! Steel-belted radial tires hug the surface below, while front and rear stabilizer bars help

keep you tracking true. What you feel is clean response and a sense of command. Quick-ratio power steering helps make maneuvering a breeze. The features—and the excitement—are standard.

If you love driving, you'll feel right at home. Cutlass Calais, the grand touring experience without the grand touring price.



Cutlass Calais features and available options drive the grand touring experience home. With Cutlass Calais, the sky's the limit. Order yours with the available removable roof panels (below). The tinted tempered glass panels can be removed quickly and stored conveniently in the trunk. The stylish outside sport

mirrors are standard. And the driver's side mirror features remote control for your convenience. The grand-touring experience begins when you lean back into a specially-contoured reclining front bucket seat (lower left). These seats are standard and you can choose between soft all-vinyl or rich velour upholstery, no extra charge.

A full complement of easy-to-read instruments help keep you informed. All standard. So is a custom sport steering wheel with handsome brushed metal spokes and thick padded grip. The storage floor console with automatic shifter (lower right), is also standard. No doubt about it. You've just got to get your hands on this one.



Cutlass Supreme
facts, figures and features.



Cutlass Supreme instrument panel with wood grain vinyl and deluxe steering wheel.



Headlamp-on reminder, standard. Sounds and flashes a warning when door is opened.

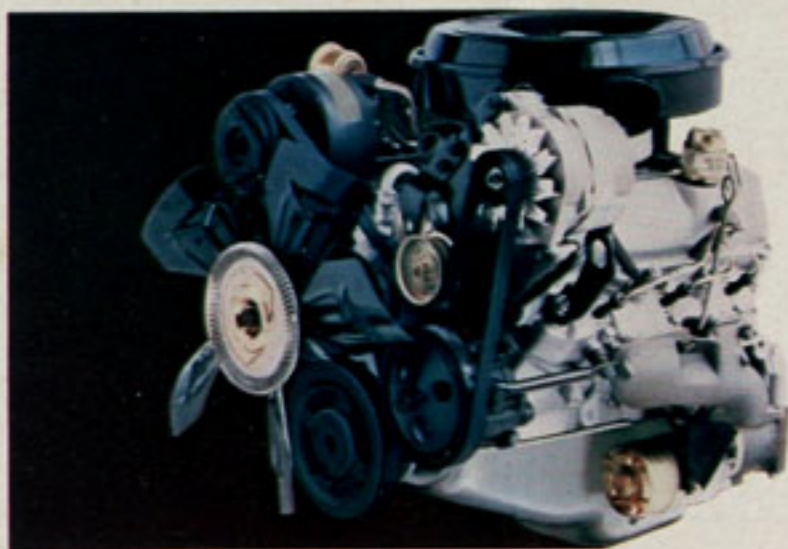

Economical diesel V-6 engine. This available 4.3-liter diesel engine is designed for impressive mileage.* A 5.7-liter diesel V-8 is also available.

See all that luggage?
It will fit neatly into
the Cutlass trunk.
Great for vaca-
tion trips.



Extensive anti-corrosion measures. Includes galvanized metals, plastisols, sealers, front fender liners, waxes and zinc-rich primers.

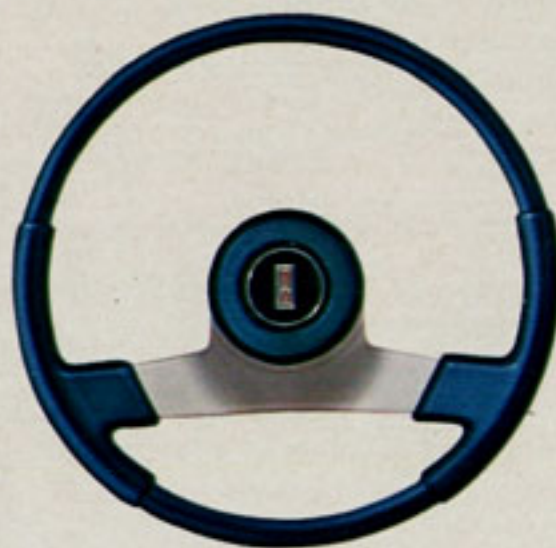

Custom sport steering wheel features padded vinyl grips and sporty metal spokes available.



Standard 3.8-liter V-6. Offers impressive fuel efficiency for Cutlass Supreme.*



Wheel Trim. (A) Standard on all models. Available: (B) Wire wheel discs with locks. (C) Super Stock wheels.

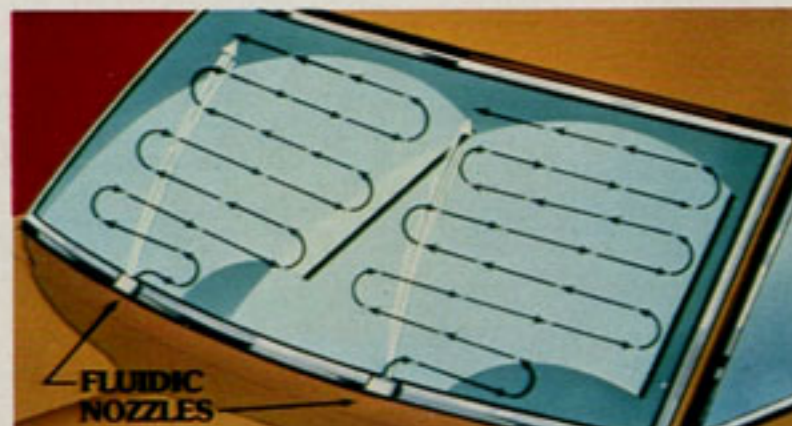

Provides an evenly distributed spray for wide coverage and good cleaning.



Halogen high-intensity high-beam headlamps for added light. Especially convenient if you do a lot of night driving. Standard on Cutlass Calais.

An inside look at Cutlass Supreme...

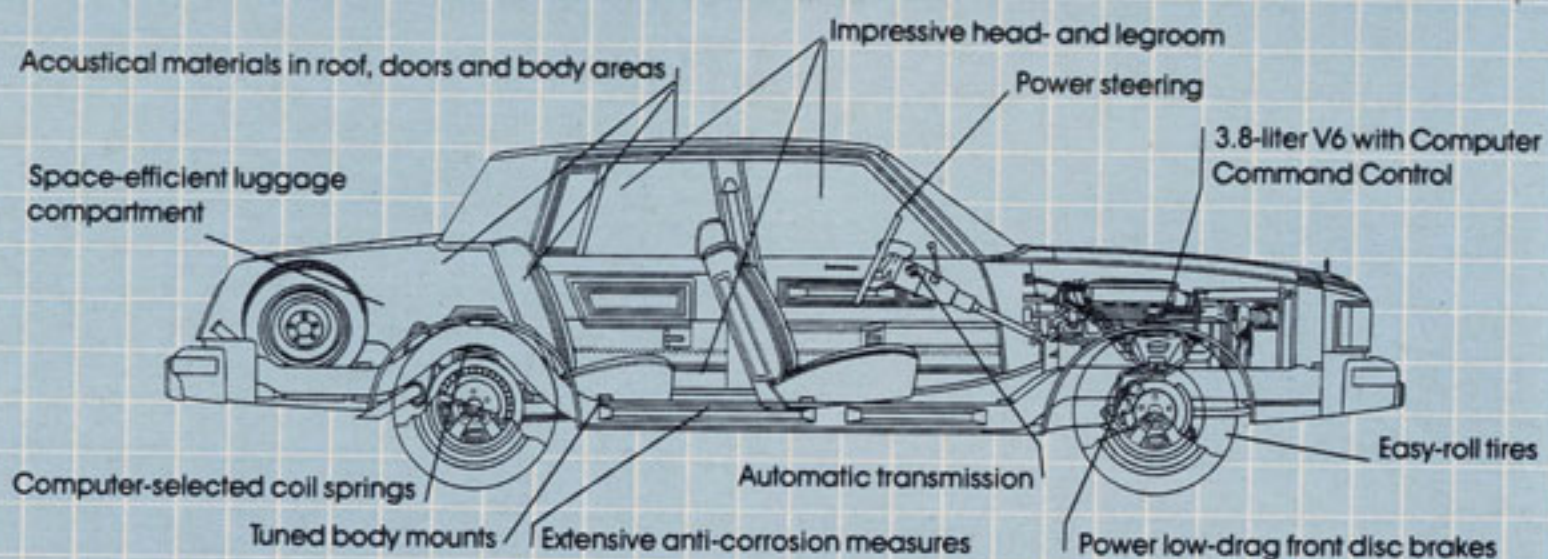

CUTLASS SUPREME STANDARD EQUIPMENT Chassis and Body:

■ Computer Command Control ■ High-Energy Ignition System ■ Power Steering ■ Low-Drag Power Front Disc Brakes ■ Computer-Selected Full Coil Springs ■ Tuned Body Mounts ■ Delcotron ■ Bumper Rub Strips with Integral Guards, Front and Rear ■ Extensive Anti-Corrosion Treatments ■ Anti-Corrosion

Front Fender Inner Liners ■ Easy-Rolling Tires ■ Automatic Transmission with Torque Converter Clutch ■ Hood Center Molding, plus Stand-Up Front-End Panel Ornament ■ Bright Roof Drip, Rocker Panel and Wheel-Opening Moldings ■ Fluidic Windshield Washer ■ Recessed Windshield Wipers ■ P195/75R14 Steel-Belted Radial-Ply Blackwall Tires ■ Deluxe Bright Wheel Discs

Interior:

■ Full-Foam Seat Construction ■ Armrests, Front and Rear ■ Cut-Pile Carpeting, Wall-to-Wall with Carpeted Lower Door Panels ■ Interior Operated Hood Lock Release ■ Simulated Butterfly Walnut Grained Instrument Panel Trim ■ Cigar Lighter ■ Headlamp-On Warning ■ Inside Day/Night Rearview Mirror ■ Deluxe Seat Belts ■ Deluxe Steering Wheel ■ Flo-Thru Ventilation ■ Automatic Lamp Switches, Front Doors ■ Front Door-Pull Handles

STANDARD EQUIPMENT BY MODEL

Cutlass Supreme Coupe and Sedan:

■ Engine, 3.8-liter V6, 2-Barrel ■ Automatic Transmission ■ Custom Sport Bench Front Seat with Center Armrest ■ Choice of Cloth Trim in Five Colors, Vinyl in Three Colors ■ Outside Rearview Mirror, Driver and Passenger Side (Coupe), Driver Side (Sedan)

Cutlass Supreme Brougham Coupe and Sedan:

■ Engine, 3.8-liter V6, 2-Barrel ■ Automatic Transmission

CUTLASS SUPREME/ CRUISER POWER TEAMS

Standard Engine:*

Liter/Type..... 3.8/V6

Carburetion..... 2-Barrel

Available Engines:*

Liter/Type..... 4.3/V6t Diesel

Liter/Type..... 5.0/V8

Carburetion..... 4-Barrel

Liter/Type..... 5.7/V8 Diesel

Standard Transmission:*

3-Speed Automatic

DIMENSIONS:

Cutlass Supreme (Coupe/Sedan)

Overall Length (in.)... 200.0/200.4

Wheelbase (in.)..... 108.1/108.1

Luggage Cap. (cu. ft.)... 16.2/16.3

Fuel Tank Gas (gals.)... 18.1/18.1

Fuel Tank Diesel (gals.)... 19.8/19.8

Headroom,

front (in.)..... 37.9/38.7

rear (in.)..... 38.1/37.8

Legroom,

front (in.)..... 42.8/42.8

rear (in.)..... 36.3/38.0

Shoulder Room,

front (in.)..... 56.6/56.7

rear (in.)..... 55.9/57.1

■ Divided Front Bench Seat with Individual Controls ■ Choice of Velour Trim in Five Colors ■ Outside Rearview Mirror, Driver and Passenger Side (Coupe), Driver Side (Sedan) ■ Convenience Group with Lamps, Visor Vanity Mirror and Chime Tones ■ Specific Brougham Ornamentation

Cutlass Calais Coupe:

■ Engine, 3.8-liter V6, 2-Barrel ■ Automatic Transmission with Floor Shift ■ Sport Console ■ Contour Reclining Front Bucket Seats ■ Choice of Cloth Trim in Five Colors, Vinyl in One Color ■ Instrument Panel Rallye Gages ■ Custom Sport Steering Wheel ■ Special Steering Gear Ratio ■ Larger Diameter Front Stabilizer Bar and Rear Stabilizer Bar ■ Tungsten Halogen Headlamps (High-Beams) ■ Wide Lower Body Moldings on Front Fenders, Door and Rear Quarter Panels ■ Outside Sport-Style Rearview Mirrors ■ Body Side Accent Stripe ■ Super Stock Wheels Color-Matched to Body with Stainless Steel Trim Rings

CUTLASS SUPREME AVAILABLE EQUIPMENT:

6-Way Power Seat Adjuster, Driver Side Bench or Bucket Seat Reclining Seat Back, Manual (Passenger Side) Contour Bucket Front Seat Divided Bench Front Seat with Individual Controls Power Door Locks

Soft-Ray Tinted Glass Power Side Windows (Available with Power Rear Door Vents for Sedans) Power Trunk-Lid Lock Release Lower Body Side Moldings Auxiliary Floor Mats with Carpet Inserts Deluxe Luggage Compartment Trim and Spare Tire Cover Bright Door-Edge Guard Moldings Full Vinyl Rooftop Coverings (Sedans) Landau Vinyl Rooftop (Cpe.) Pulse Wiper System Electric Sliding Glass Sunroof (Cpe.) (Reduces headroom slightly) Removable Glass Roof Panels (Cpe.) Electric Rear Window Defogger Air Conditioner—Four-Season Sail Panel Opera Lamps (Sedans) Dome and Reading Lamp Comb. Remote Control Outside Rearview Mirrors

Sport Console with Transmission Shifter (Bucket Seats required, Cpe.) Illuminated Visor Vanity Mirror Genuine Sierra Leather Trim in the seating areas (Brougham models) Body Accent Color Stripes Limited Slip Differential Engine Block Heater Cruise Control with Resume Feature Custom Sport Steering Wheel Tilt-Away Steering Wheel Super Stock Wheels, Color-Keyed Wire Wheel Discs with Locks Tires, P205/70R14 Steel-Belted Radial-Ply White-Stripe Tires, P195/75R14 Steel-Belted Radial-Ply White-Stripe Tires, P205/70R14 Steel-Belted Radial-Ply Blackwall with Raised White Letters Convenience Group including Lamps, Visor Vanity Mirror and Chime Tones Tungsten Halogen Headlamps High-Capacity Battery Digital or Regular Quartz Clock Instrument Panel Gage Clusters Trip Odometer (Included in Cluster) External Lamp Monitors Two-Tone Paint Scheme Firm Ride and Handling Package Heavy-Duty Wheels 5-Wire Trailer Wiring Harness High-Capacity Cooling Systems Radios and Tape Players (See Page 30)

*See EPA mileage estimates in accompanying Fuel Economy Estimate/Engine Supplement Sheet.

A drive in the country. Or a night on the town. Getting the job done—with style. A tradition that it's right at home with. One drive and you quickly learn that Cutlass Cruiser is an Oldsmobile. Good looking, smooth riding, elegant and comfortable. But bring on the chores and you also discover a very willing worker—with up to 71.8 cubic feet of cargo area—with rear seat back folded down. Practically priced, it's a great wagon for today.

CUTLASS CRUISER



An inside look at Cutlass Cruiser...

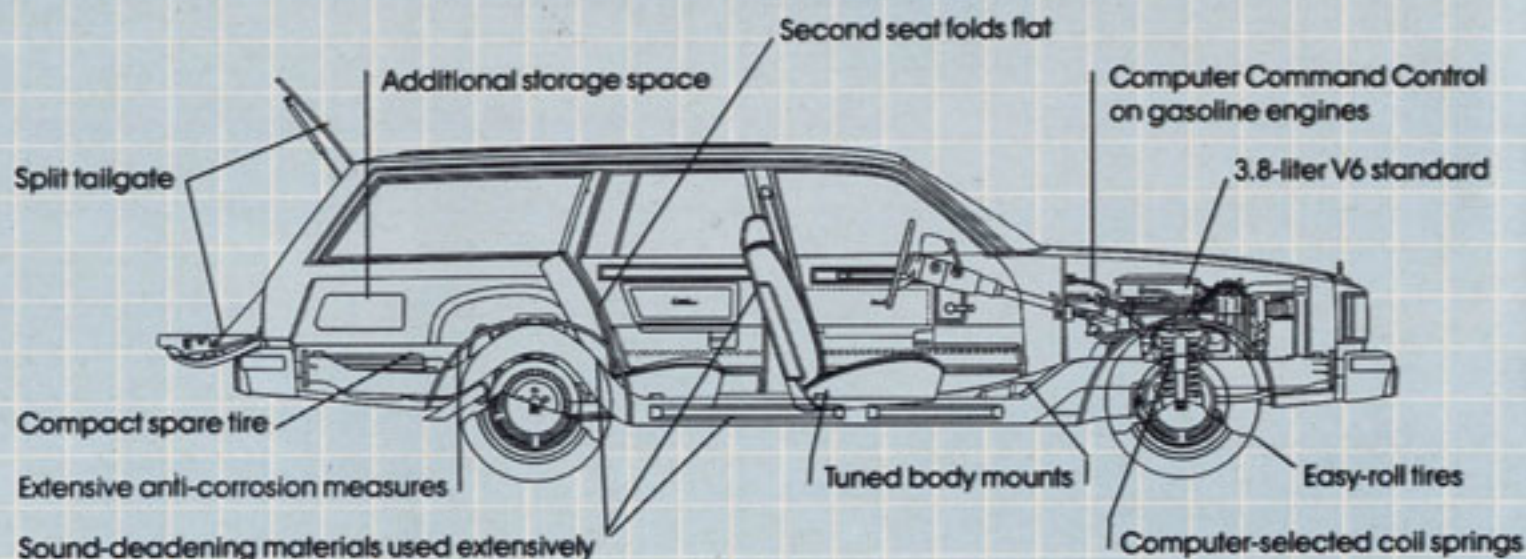

CUTLASS CRUISER STANDARD EQUIPMENT

Chassis and Body:

- Computer Command Control
- High-Energy Ignition System
- Power Steering
- Low-Drag Power Front Disc Brakes and Rear Drums
- Computer-Selected Full Coil Springs, Front and Rear
- Tuned Body Mounts
- Delcotron
- Bumper Rub Strips with Integral Guards, Front and Rear
- Anti-Corrosion Treatments
- Anti-Corrosion Front Fender Inner Liners
- Easy-Rolling Tires
- Automatic Transmission with Torque Converter Clutch
- Hood Center Molding, plus Stand-Up Front-End Panel Ornament
- Bright Roof Drip, Rocker Panel and Wheel-Opening Moldings
- Fluidic Windshield Washer
- Recessed Windshield Wipers
- P195/75R14 Steel-Belted Radial-Ply Blackwall Tires
- Deluxe Bright Wheel Discs.

Interior:

- Full-Foam Seat Construction
- Armrests, Front and Rear
- Cut-Pile Carpeting, Wall-to-Wall with Carpeted Lower Door Panels and Cargo Area
- Interior Operated Hood Lock Release
- Simulated Butterfly Walnut Grained Instrument Panel Trim
- Cigar Lighter
- Headlamp-On Warning
- Inside Day/Night Rearview Mirror
- Deluxe Seat Belts, Color-Keyed to Individual Interiors
- Deluxe Steering Wheel
- Flo-Thru Ventilation
- Automatic Lamp Switches, Front Doors
- Front Door-Pull Handles
- Central Dome and Tailgate Dome Lamps—Tailgate has Separate Rear Switch.

Cutlass Cruiser 2-Seat Wagon:

- Engine, 3.8-liter V6, 2-Barrel
- Automatic Transmission with Torque Converter Clutch and Column Shift
- Custom

- Sport Bench Front Seat with Center Armrest
- Choice of Cloth Trim in Five Velour Colors, Vinyl in Three Colors
- Wall-to-Wall Carpeting including Lower Door Panels and Cargo Area.

CUTLASS CRUISER AVAILABLE EQUIPMENT:

- 6-Way Power Seat Adjuster (Divided Bench, Driver Side)
- 6-Way Power Seat Adjuster (Standard Bench)
- Reclining Seat Back, Manual (Passenger Side)
- Divided Bench Front Seat with Individual Controls
- Power Door Locks
- Power Tailgate Lock Release
- Soft-Ray Tinted Glass
- Power Side Window (Available with Power Rear Door Vents)
- Lower Body Side Moldings
- Auxiliary Floor Mats with Carpet Inserts, Front and Rear
- Bright Door-Edge Guard Moldings

- Pulse Wiper System
- Electric Rear Window Defogger
- Air Conditioner—Four-Season
- Dome and Reading Lamp Combination
- Remote Control Outside Rearview Mirrors, Driver only, or Driver and Passenger Side
- Illuminated Visor Vanity Mirror, Passenger Side
- Limited Slip Differential
- Engine Block Heater
- Automatic Cruise Control with Resume Features
- Custom Sport Steering Wheel
- Body Side Accent Stripes
- Body Side and Tailgate Wood

Grain Vinyl Panels

- Locks for Tire Stowage and Rear Quarter Stowage Compartments with Doors
- Rooftop Luggage Carrier
- Rear Window Air Deflector
- Tilt-Away Steering Wheel
- Super Stock Wheels—Color-Keyed to Body Color
- Simulated Wire Wheel Discs with Locks
- Puncture-Sealing Tires
- Tires, P205/70R14 Steel-Belted Radial-Ply White-Stripe
- Tires, P195/75R14 Steel-Belted Radial-Ply White-Stripe
- Tires, P205/70R14 Steel-Belted Radial-Ply Blackwall with Raised White Letters
- Convenience Group including Lamps, Visor Vanity Mirror and Chime Tones
- Tungsten Halogen Headlamps (High-Beams)
- High-Capacity Battery
- Digital Display or Regular Quartz Clocks
- Instrument Panel Gage Clusters
- Trip Odometer
- External Lamp Monitors, Front and Rear
- Firm Ride and Handling Package
- Heavy-Duty Wheels
- 5-Wire Trailer Electrical Wiring Harness
- High-Capacity Cooling Systems
- Radios and Tape Players (See Page 30)

CUTLASS CRUISER POWER TEAMS

Standard Engine:*

Liter/Type 3.8/V6

Carburetion 2-Barrel

Available Engines:*

Liter/Type 5.0/V8

Carburetion 4-Barrel

Liter/Type 5.7/V8

Diesel

Standard Transmission:*

Automatic w/Torque Converter

Clutch

DIMENSIONS:

Overall Length (in.) 200.4

Wheelbase (in.) 108.1

Cargo Cap. (cu. ft.) 71.8

Fuel Tank, Gas (gals.) 18.2

Fuel Tank, Diesel (gals.) 18.2

Headroom,

front (in.) 38.8

rear (in.) 38.8

Legroom,

front (in.) 42.8

rear (in.) 35.5

Shoulder Room,

front (in.) 56.7

rear (in.) 57.1



Easy does it! Convenient split tailgate and carpeted cargo area.

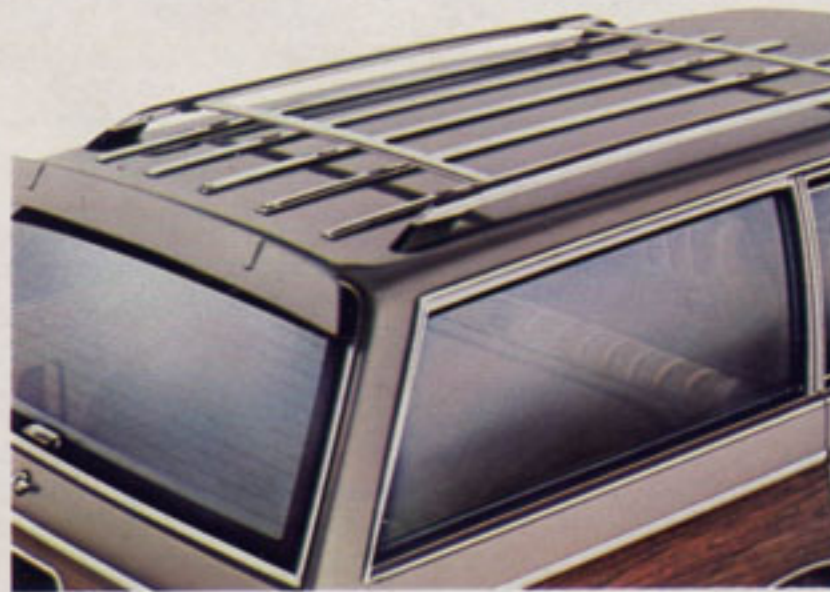

Room at the top! Available roof rack adds to the cargo space.



Out of sight! Hidden compartment/spare tire storage helps conceal and protect valuables.

**Diesel economy.
At Oldsmobile, it comes in
all shapes and sizes.**

In 1977, Oldsmobile became the first to introduce diesel V8 economy* in American passenger cars with the 5.7-liter diesel V8. Then, in 1982, Oldsmobile introduced another first: the world's first transverse-mounted 4.3-liter diesel V6 in passenger cars. As a result, people all across America have made Oldsmobile the number one choice in diesel cars.

Over 500,000 Olds owners have discovered the advantages of a diesel. For starters, they discovered that a diesel car can offer up to 30% better

fuel economy than a gas engine of comparable size. And do it on diesel fuel. These fuel-efficient engines with their added capacity fuel tanks provide extra driving range between stops.

Olds offers 20 ways to enjoy diesel style and comfort. For instance, you can enjoy diesel V8 economy in a roomy, comfortable Oldsmobile Delta 88, Custom Cruiser wagon, elegant Ninety-Eight Regency and the luxurious Toronado Brougham.

But what about Cutlass Supreme, America's most popular mid-size car? You can get the diesel V8 or the conventionally mounted version of the V6 on all five Supreme coupes and sedans.

In addition, the diesel V8 is available on Cutlass Cruiser.

The transverse-mounted version of the diesel V6 is ideally suited for the new front-wheel drive Cutlass Ciera, and is available on all four Ciera models.

The diesel Olds difference. When it comes to advancing the cause of diesel economy, Oldsmobiles offer some very important advantages. For example, you'll notice a certain smoothness as a result of the V-type design. There's also a water/fuel separation



system with warning light. Roller hydraulic lifters. Plus 4-speed overdrive automatic transmission on some models.

For quick starting, every diesel-equipped Oldsmobile features the Fast-Start Glow Plug System. It's a proven system that gives quick, easy starting in cold or damp weather. This efficient system features miniature heating elements that preheat the pre-chamber area around the fuel injection nozzle to aid combustion when the car is started. Its importance really pays off in climate

where the mercury dips below freezing and stays there for months on end. For example, at 0°F a diesel Olds is ready to start in about eight seconds or less.

Maintaining your diesel-equipped Olds is simple, too. The only special maintenance attention recommended for your diesel is an oil and oil filter change every 5,000 miles, and crankcase ventilation check every 15,000 miles. Other than that, its service schedules are similar to other Oldsmobiles—except that there are no spark plugs, no carburetor and no distributor.

Oldsmobile offers a diesel-equipped passenger car to fit your needs. And right now there's no better time to talk to

your Oldsmobile dealer about how a diesel Olds can benefit you.

Better yet, there's no better time to drive a diesel Oldsmobile. You'll find that a diesel Olds gives you room to stretch out in comfort, while you get the fuel economy of many smaller cars.

New 3 year/50,000 mile Power Protection Plus limited warranty on diesel engines. See your Olds dealer for details.

Oldsmobile

America's #1 Seller of Diesels.



Oldsmobile Diesel

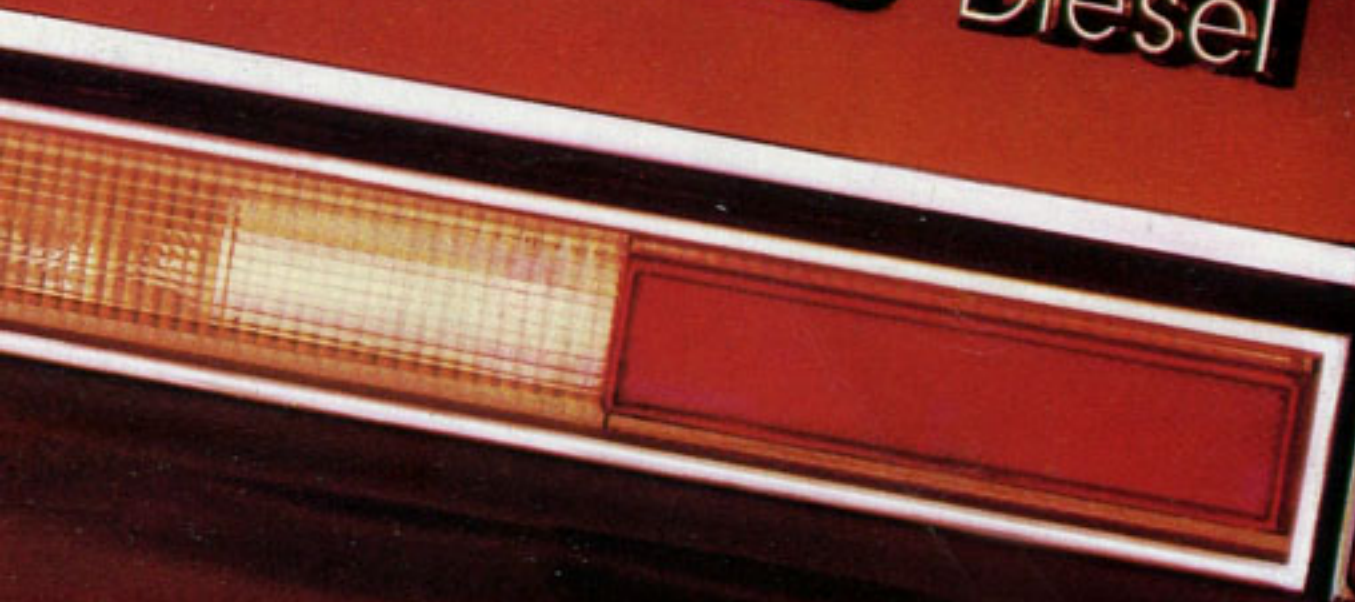

Now there are 30 beautifully
engineered Oldsmobile models
designed to be at home
anywhere in America.
At home anywhere you are.

Toronado Brougham
Ninety-Eight Regency Brougham Sedan
Ninety-Eight Regency Sedan
Ninety-Eight Regency Coupe
Delta 88 Royale Brougham Sedan
Delta 88 Royale Brougham Coupe
Delta 88 Royale Sedan
Delta 88 Royale Coupe
Delta 88 Sedan
Custom Cruiser
Cutlass Ciera Brougham Sedan
Cutlass Ciera Brougham Coupe
Cutlass Ciera LS Sedan
Cutlass Ciera LS Coupe
Cutlass Supreme Brougham Sedan
Cutlass Supreme Brougham Coupe
Cutlass Calais Coupe
Cutlass Supreme Sedan
Cutlass Supreme Coupe
Cutlass Cruiser
Omega Brougham Sedan
Omega Brougham Coupe
Omega Sedan
Omega Coupe
Firenza LX Sedan
Firenza SX Coupe
Firenza Sedan
Firenza S Coupe
Firenza Cruiser
Firenza LX Cruiser

Oldsmobile

Have one built for you.